

## WRB-S-3W and WRA-S-3W series

3W , 1500VDC Isolated regulated single-channel/positive and negative output DC-DC module power supply

- ◆ Ultra-wide input voltage range: 4:1
- ◆ Low standby power consumption: 0.15W(typ)
- ◆ Low ripple noise: 50mV(typ)
- ◆ Input under-voltage protection
- ◆ Output short-circuit protection (self-recovery)



- ◆ 工作温度: -40°C ~ +85°C

*This series of module power supplies is suitable for power circuit applications where the input voltage varies greatly and the input and output must be isolated. Its features such as an ultra-wide input voltage range (4:1), highly stable output voltage, low ripple noise, and high efficiency and reliability make it particularly suitable for use in power systems such as industrial control systems, communication systems, power monitoring systems, and instrument and meter power supplies.*

Selection table

Model	Nominal value of input voltage	Input voltage range	Output the nominal voltage	Output rated load	Full-load efficiency (%_typ)	Maximum capacitive load (μF)
WRB2403S-3WR2	24V	9.0-36V	3.3V	750mA	76	2200
WRB2405S-3WR2			5.0V	600mA	81	1000
WRB2409S-3WR2			9.0V	333mA	83	680
WRB2412S-3WR2			12V	250mA	85	470
WRB2415S-3WR2			15V	200mA	85	330
WRB2424S-3WR2			24V	125mA	85	220
WRA2405S-3WR2			±5.0V	±300mA	80	±470
WRA2412S-3WR2			±12V	±125mA	83	±220
WRA2415S-3WR2			±15V	±100mA	83	±150
WRA2424S-3WR2			±24V	±63mA	83	±100
WRB4803S-3WR2	48V	18-75V	3.3V	750mA	76	2200
WRB4805S-3WR2			5.0V	600mA	81	1000
WRB4809S-3WR2			9.0V	333mA	83	680
WRB4812S-3WR2			12V	250mA	85	470
WRB4815S-3WR2			15V	200mA	85	330
WRB4824S-3WR2			24V	125mA	85	220
WRA4805S-3WR2			±5.0V	±300mA	80	±470

WRA4812S-3WR2			±12V	±125mA	83	±220
WRA4815S-3WR2			±15V	±100mA	83	±150
WRA4824S-3WR2			±24V	±63mA	83	±100

Product characteristics						
Project	Working conditions	Min	Typ	Max	Unit	
Input current (full load/no-load)	24V nominal input series	--	150/5	--	mA	
	48V nominal input series	--	78/2	--		
Starting voltage	24V nominal input series	--	--	9	V	
	48V nominal input series	--	--	18		
Startup time	Nominal input voltage @ Full load (Resistive load)	--	8	--	ms	
Under-voltage shutdown	24V nominal input series	--	7.0	--	V	
	48V nominal input series	--	15	--		
Remote control output ON/OFF	Module output ON	CTRL is left floating or connected to a high level (2V-Vin).				
	Module output OFF	CTRL connected to GND or low level (0-0.5V)				
	Input current when turned off	--	2	--	mA	
Output voltage accuracy	@0-100% load	-2	±1	+2	%	
Linear adjustment rate	@Fully loaded, Vin_min to Vin_max	-0.5	±0.3	+0.5		
Load adjustment rate	@ Nominal input, 10%-100% load	-1.0	±0.5	+1.0		
Dynamic response deviation	Nominal input @ load varies by 50%-75%-50%	--	±5	±8		
Dynamic recovery time	Nominal input @ load varies by 50%-75%-50%	--	300	500	µs	
Ripple & Noise	20MHz bandwidth @Vin_nom, 100% load	--	50	100	mVp-p	
Short-circuit protection		Sustainable and self-recovering				
Overcurrent protection	Vin@Vin_min	110	--	150	%	
Temperature drift coefficient	Nominal input @100% load	--	±0.03		%/°C	
Insulation voltage	Input-output, 60 seconds @ leakage current ≤1mA	1500	--	1700	VDC	
Insulation resistance	Input-output, test voltage 500VDC	1000	--	--	MΩ	
Isolation capacitor	Input-output, 100KHz/0.1V	--	2200	--	pF	
Switching frequency	100% load @Vin_nom	--	300	--	KHz	
Working environment temperature	Meet the requirements of temperature derating	-40	--	+85	°C	

The working temperature rise of the product	100% load @Vin_nom, Ta=25°C	--	30	--	
Storage temperature		-55	--	+125	
Storage humidity	No condensation	--	--	95	%RH
MTBF	MIL-HDBK-217F@25°C	1000	--	--	KHours
Welding temperature	Manual welding	370±10°C @3 ~ 5Sec			
	Wave soldering welding	260±10°C @5 ~ 10Sec			
Hot plugging		Not supported			
Cooling method		Natural air cooling			
Shell material		Black flame-retardant plastic shell			

### Product EMC characteristics

EMI	Transmitted harassment	CISPR32/EN55032 CLASS B		
	Radiation disturbance	CISPR32/EN55032 CLASS B		
EMS	Electrostatic discharge	IEC/EN61000-4-2	Contact±4KV	Perf.Criteria B
	Radiation immunity	IEC/EN61000-4-3	10V/m	Perf.Criteria A
	Impulse group immunity	IEC/EN61000-4-4	±2KV	Perf.Criteria B
	Surge immunity	IEC/EN61000-4-5	line to line ±2KV	Perf.Criteria B
	Conducted disturbance immunity degree	IEC/EN61000-4-6	3Vrms	Perf.Criteria A
	Voltage sag, sag and short-term interruption immunity	IEC/EN61000-4-29	0, 70%	Perf.Criteria B

Note: Refer to the EMC recommended circuit test

### Characteristic curve

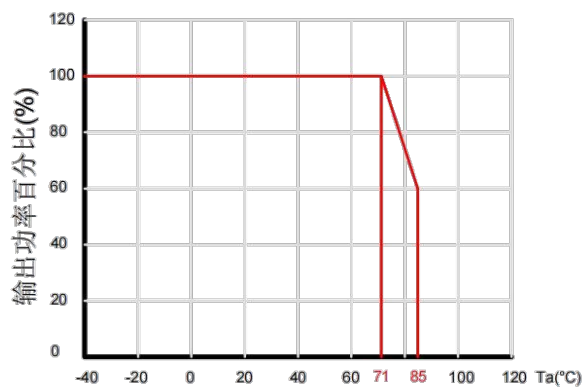

Temperature derating curve

## Precautions for Use

### 1. Considerations for additional input capacitors:

There are various kinds of interference noises in the power input terminal line, which have high frequencies, short durations, but very high peaks. In order to make the power supply work stably and reliably, it is usually necessary to add an appropriate absorption capacitor externally at its input terminal. There are also some cases where the lead wire between the power supply and the power supply on the PCBA board is very long. In such cases, a filter capacitor must be connected in parallel to the input pin of the power supply to achieve impedance matching. The greater the interference noise and the longer the line, the greater the required additional capacitance value. Our company recommends the use of high-frequency and low-resistance electrolytic capacitors. For general applications, the recommended values in the "Design Reference Section" can be used for selection.

### 2. Considerations for additional output filter capacitors:

In actual application circuits, the load size of the power supply varies, and it is usually accompanied by changes of varying magnitudes. In order to make it adapt to different usage scenarios and load requirements and work more stably and reliably, an appropriate capacitor needs to be added externally at the output end of the power supply. On the one hand, the output ripple and noise need to be further reduced; On the other hand, an external output capacitor is applied to reduce the fluctuation of output voltage amplitude caused by load jumps, making the output voltage more stable. However, a capacitor of excessive capacity should not be added to the output end. The larger the output capacitance, the greater the instantaneous current that needs to be provided by the power supply end when the power starts up, and it may even cause the output voltage to fail to be established. In addition, if the capacitance value applied at the output terminal is too large, the power supply is prone to output overshoot when starting up. Therefore, in order to ensure the power supply operates more stably and reliably, the capacity of the output capacitor should be reduced as much as possible when the amplitude of the output voltage fluctuation caused by the load jump meets the requirements. The maximum capacitive load in the selection list only indicates that the power supply can start normally when the total capacitance at its output terminals is within this value. We do not recommend its use.

Our company recommends the use of high-frequency and low-resistance electrolytic capacitors. For the recommended values, please refer to the "Design Reference Section".

### 3. Prevent hot-swappable testing or use of power modules

When the power supply is not disconnected, plugging the power into the circuit or removing it from the circuit is performing a hot plugging operation. Hot plugging operation is not supported during the use or testing of the power supply. Because during the hot-swapping process, due to the sudden change of current, high-voltage spikes will be generated, which may cause damage to it.

Another situation is to connect a mechanical switch in series between the power supply and the input end of the power supply product, and control the on and off of the power supply through the mechanical switch. Mechanical switches can also generate high-voltage spikes during on-off operations, which may also cause damage to the power supply.

During the testing or usage of power supply products, any operation that generates high-voltage spikes cannot be ignored. Measures need to be taken to prevent high-voltage spikes from being directly applied to their input terminals. For reference, please refer to the "Design Reference Section".

#### 4. Protection against high transient voltage spikes at the input terminal:

If the product is used in an environment with relatively severe electromagnetic interference, such as the input end of the product sharing the power supply with inductive loads, or the power supply end

When the current loop of the device is switched on or off, if not handled properly, there will be high transient voltage spikes parasitizing on the power supply loop. If this interference is not dealt with, the excessively high peak voltage entering the product input end is very likely to cause product damage. The suppression of high-voltage spikes is of great significance for ensuring the stable and reliable use of the product. Commonly used transient voltage suppression devices include varistors (MOV) and transient voltage suppression diodes (TVS), etc.

Different devices have their own advantages and disadvantages. Please select them based on the application scenarios and requirements. You can refer to the "Design Reference Section".

#### 5. Requirements for load balance of positive and negative outputs:

The actual load of positive and negative output products usually shows an imbalance between the two loads. In this case, the negative output voltage of the product will vary with the changes of the two loads. When the main circuit load is constant, the negative output voltage will increase as its load decreases and decrease as the load increases. When the negative output load is constant, the negative output voltage will decrease as the positive output load decreases and increase as the positive output load increases. If the positive output load is much smaller than the negative output load, it may even cause the product to fail to work properly.

In practical applications, it is necessary to fully consider whether the extreme situations of the two loads meet the requirements, and to improve the balance of the two loads as much as possible to make the product work more stably and reliably.

#### 6. Input polarity and output power expansion:

The input end of the product does not have reverse connection protection. Please note: Reversing the input polarity during use may cause damage to the product. To achieve reverse connection prevention or non-polar use without damaging the product, a diode or rectifier bridge can be connected in series at the input end. For reference, please refer to the "Design Reference Section". In addition, the product does not support output parallel connection to expand output power. Please choose our company's products of a higher power level.

### Design reference

#### 1、Application circuit:

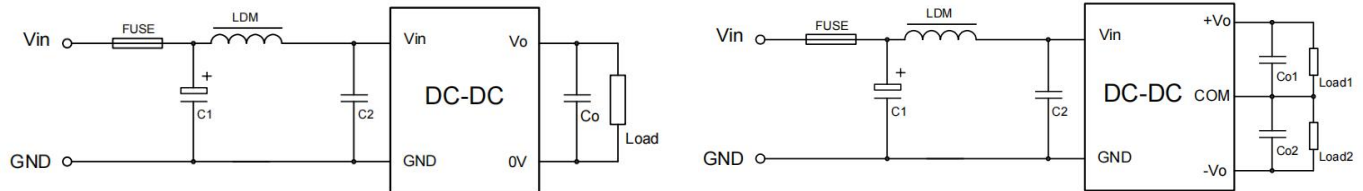

Vin	C1	C2(MLCC)	LDM	Vo	Co	Vo	Co/Co1/Co2
24V	220uF/50V	4.7uF/50V	4.7uH/2.2A	3.3V	470uF/10V	24V	47uF/50V
48V	100uF/100V	1uF/100V	10uH/1.0A	5V	330uF/16V	±5V	±220uF/16V
				9V	220uF/25V	±12V	±47uF/25V
				12V	100uF/25V	±15V	±33uF/35V
				15V	100uF/25V	±24V	±22uF/50V

External capacitance values (Table 1)

Note: It is recommended to use high-frequency and low-resistance electrolytic capacitors for input and output, whose capacitance values can be referred to (Table 1). MLCC capacitors can also be used for output. The external capacitor should be as close as possible to the input and output pins of the product. A 0.1uF ceramic capacitor is added on the basis of using high-frequency electrolytic capacitors.

#### 2、CTR LPin function:

The product has an output ON/OFF control function, which is achieved by controlling the level of the "CTRL" pin. When the "CTRL" pin is left floating or connected to a high voltage, the product outputs normally. When the "CTRL" pin is connected to GND or low voltage, the product output is off. This pin can be directly connected to the TTL control circuit.

#### 3、Input reverse connection prevention application circuit:

The input reverse connection protection function can be achieved by using the circuit in Figure (1). The circuit shown in Figure (2) can be adopted to achieve non-polar input use. Among them, for diode D1, it is recommended to use a Schottky diode with a small on-voltage drop, and for rectifier bridge BD1, it is recommended to use a rectifier bridge with a low voltage drop. If the conduction pressure drop is large, during the usage process, the loss will be high and the heat generation will be severe. The rated voltage and current of diode D1 and rectifier bridge BD1 should have sufficient margin, and the current must meet the temperature derating requirements.

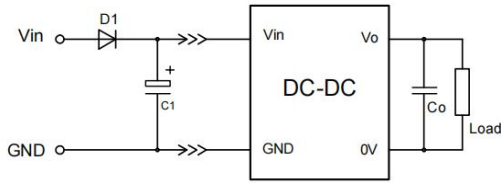

Figure (1)

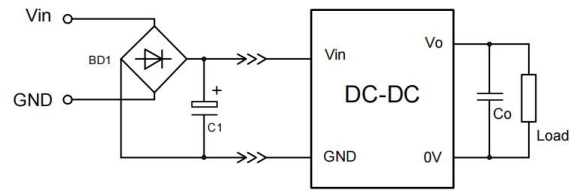
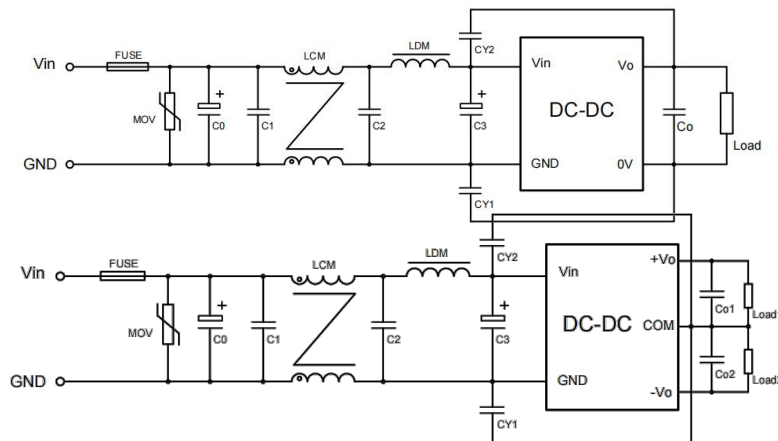

Figure (2)

#### 4、EMC Recommended circuit:



Component parameter description :		
Component code	WRB24xxS-3WR2	WRB48xxS-3WR2
FUSE	Select according to the actual current size	
MOV	20D470K	14D101K
C0 C3	470uF/50V	220uF/100V
C1 C2	4.7uF/50V	4.7uF/100V
LCM	10mH	10mH
LDM	4.7uH	10uH
CY1 CY2	1nF/2KV	1nF/2KV
Co	Selected based on (Table 1)	

### Appearance dimensions and pin functions

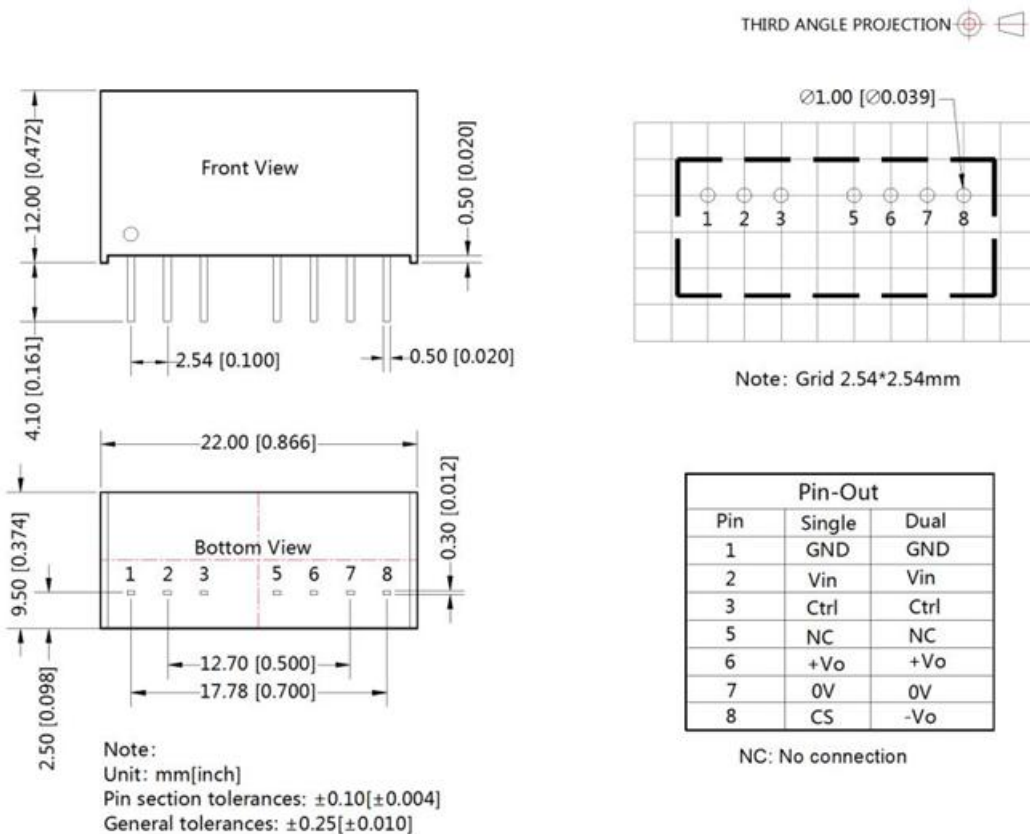

**Note:**

For the specific packaging information of our company, please refer to the "Product Shipping Packaging Instructions".

2. If the working load of the product is lower than the minimum load requirement, our company cannot guarantee that the product performance can meet all performance indicators.
3. The maximum capacitive loads were all tested within the input voltage range, with full output load, and in the CR mode of electronic load.
4. Unless otherwise specified, all indicators in this manual are measured at Ta=25°C, humidity <75%RH, nominal input voltage and output rated load.
5. All the indicator testing methods in this manual are based on the enterprise standards of our company.
6. Our company can provide product customization. For specific details, you can directly contact our technical personnel.
7. Product involvement in laws and regulations: See "Product Features" and "EMC Characteristics";
8. After our company's products are scrapped, they must be classified and stored in accordance with ISO14001 and relevant environmental laws and regulations, and handed over to qualified units for handling.