

3030 Nature 4000K White SMD LED (1W 6V)

Part No.: LLS3030NWZ-1W 6V

·Package Dimensions

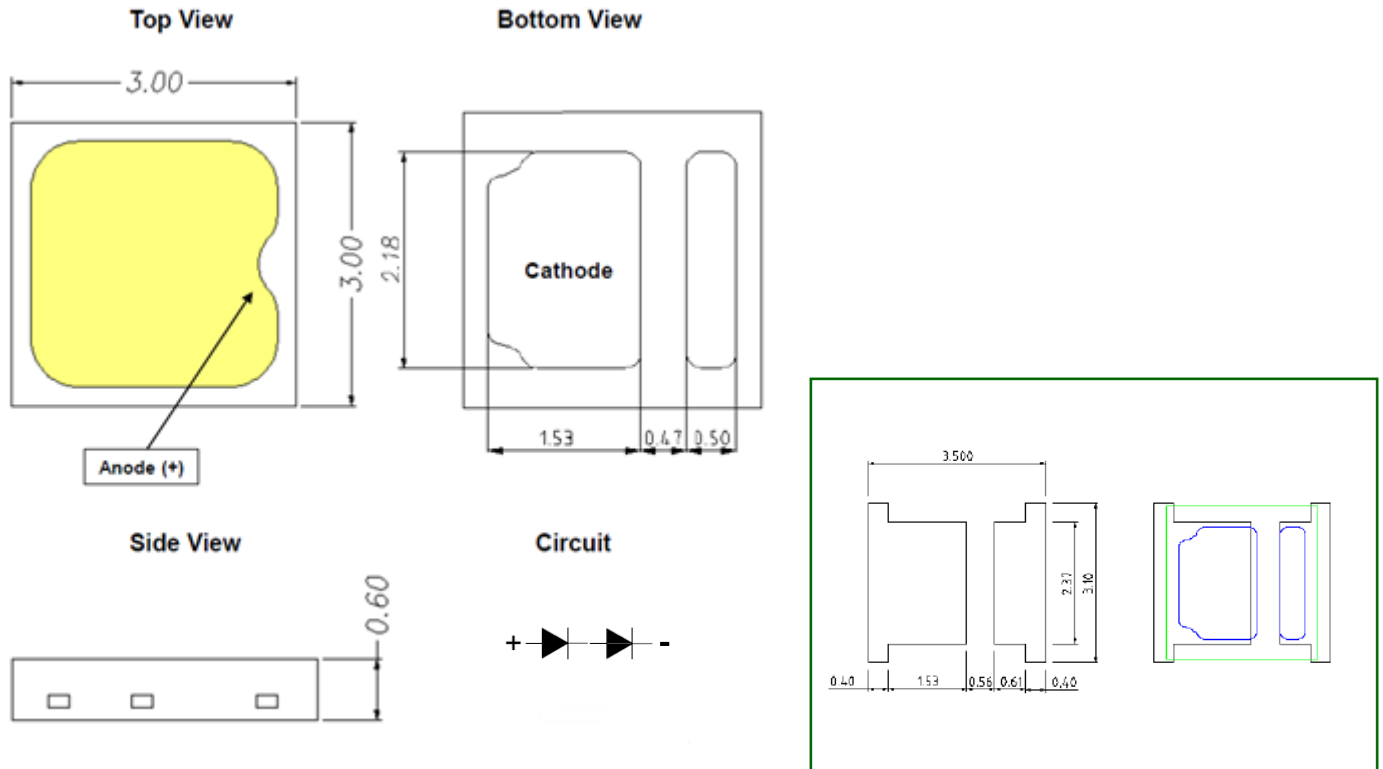

·Features:

- 3.0mm×3.0mm SMT LED,0.6mm thickness
- High reliability
- Low operating voltage, Low power consumption, long life
- PB Free products (Compliant with EU's RoHS)
- **Light Color:** Nature White.

·Application

- Bulb & Downlight & headlamp
- Other indoor & outdoor light
- Advertising backlighting
- General use

Absolute Maximum Ratings (Ta=25°C)

Item	Symbol	Maximum	Unit
Power Dissipation	P _d	1000	mW
Forward Current	I _F	400	mA
Junction temperature	T _j	125	°C
Operating Temperature Range	T _{opr}	-40 to +85	°C
Storage Temperature Range	T _{stg}	-40 to +80	°C

Electrical/Optical Characteristics (Ta=25°C)

Item	Symbol	Condition	Min.	Typ.	Max	Unit
Forward Voltage	V _F	I _F =150mA	5.9	--	6.1	V
Viewing Angle	2θ _{1/2}	I _F =150mA	-	120	-	deg
Color temperature	CCT	I _F =150mA	4000	--	4200	K
Luminous flux	IV	I _F =150mA	142	--	152	lm
Electric thermal resistance	R _{th(j-s)}			10		°C/W
Reverse Current	I _R	V _R =5V	-	-	--	uA

Typical Electro-Optical Characteristics Curves

Fig 1. Color Spectrum, $T_j = 25^\circ\text{C}$

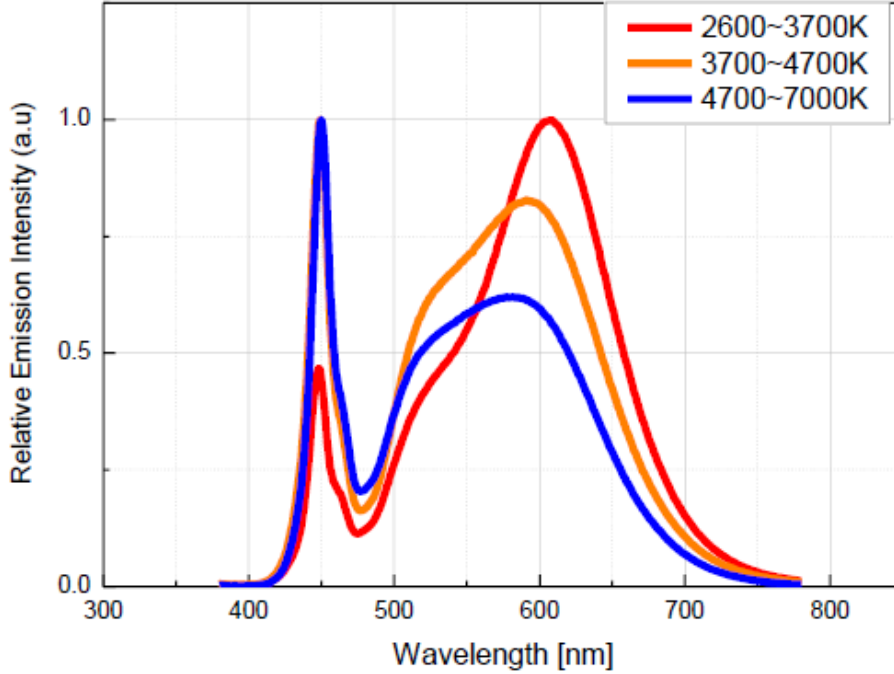

Fig 2. Radiant Pattern, $T_j = 25^\circ\text{C}$

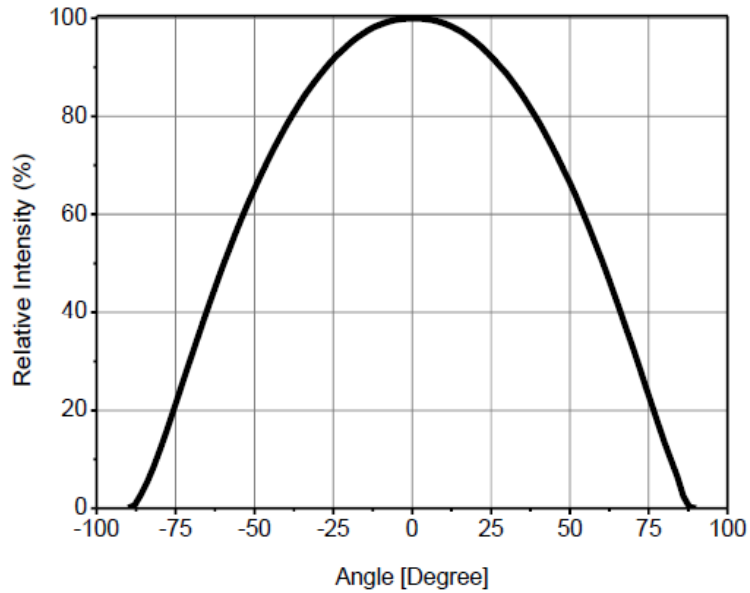

Fig 3. Forward Voltage vs. Forward Current, $T_j = 25^\circ\text{C}$

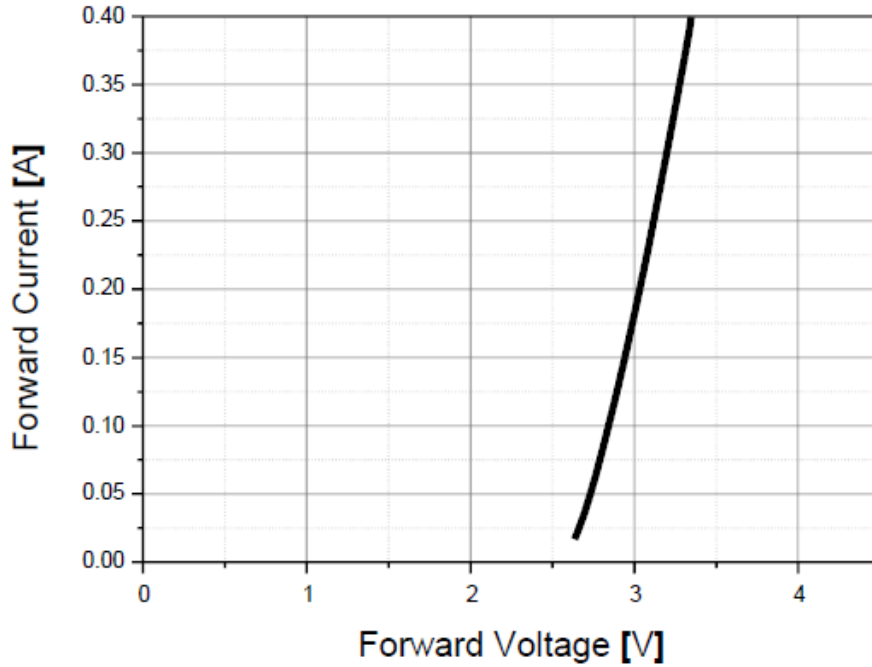
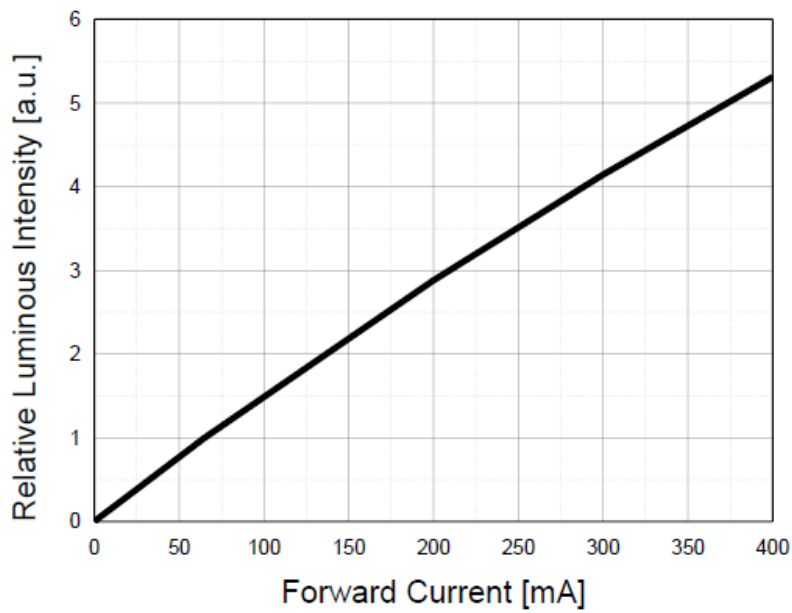

Fig 4. Forward Current vs. Relative Luminous Intensity, $T_j = 25^\circ\text{C}$



·Reliability test items and conditions

NO.	Test item	Applicable standard	Test conditions	Samples qty	AC/Re
1	High Temperature Life	JESD22-A108	Test if=DC 300mA Temp.=+85°C Test time=1000hrs	22	0/1
2	High temperature High humidity life	JEITAED-4701 100 103	Test if=DC 300 mA Temp.=+85°C RH=85% Test time=1000hrs	22	0/1
3	Thermal shock	MIL-STD-202G	-40°C to +100°C 15min to 15min Test time=100 cycles	22	0/1
4	Sulfur test	Jufei standard	1g sulfur powder/250ml 85°C/4hr	10	0/1
5	Reflow soldering	JEITAED-4701 300 301	Operation heating 260°C(max.) Within 10 seconds. Max.	22	0/1

Note: 1. Judgment criteria of failure for the reliability

2. Flux: Below 70% of initial values

3. Vf: Over 20% of upper limit value

·Package information(unit:mm)

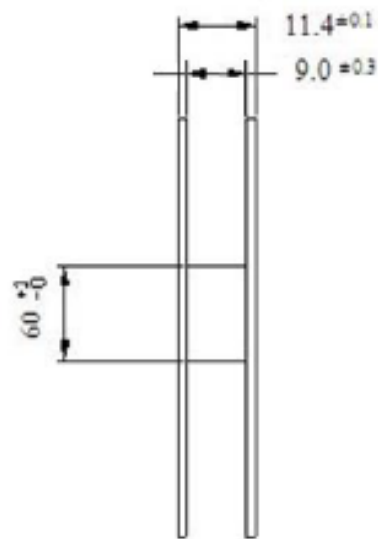
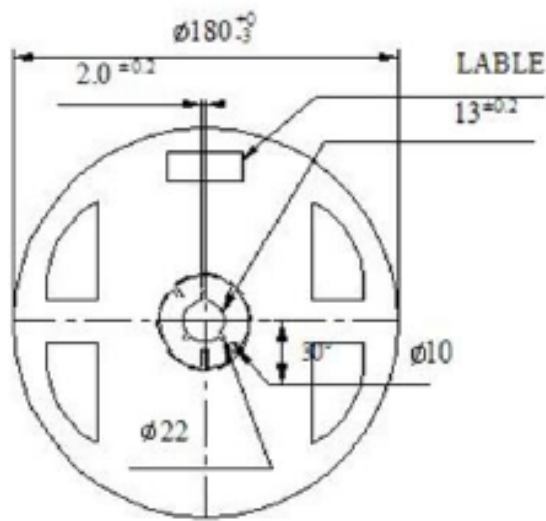
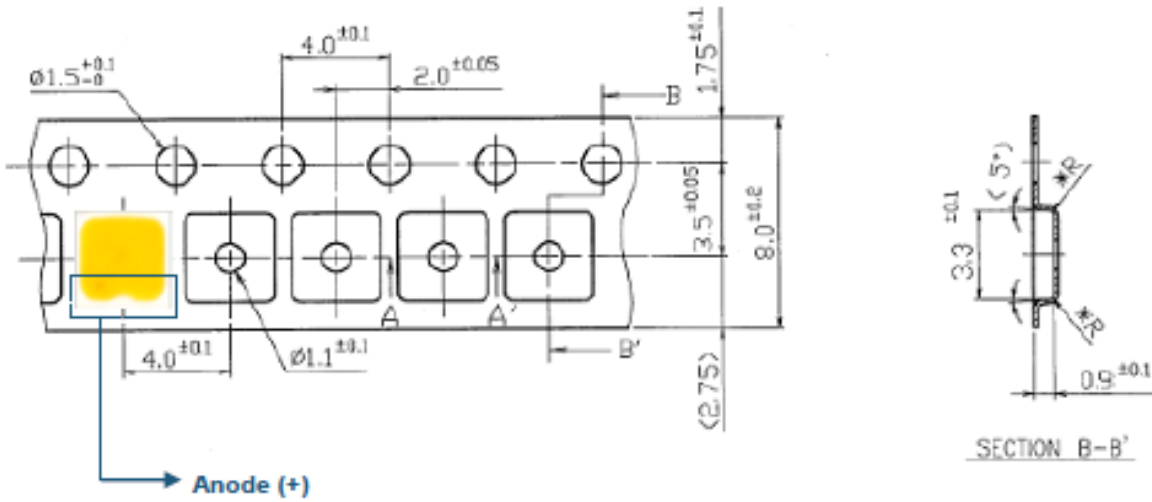

(Tolerance: ± 0.2 , Unit: mm)

·Precautions for use

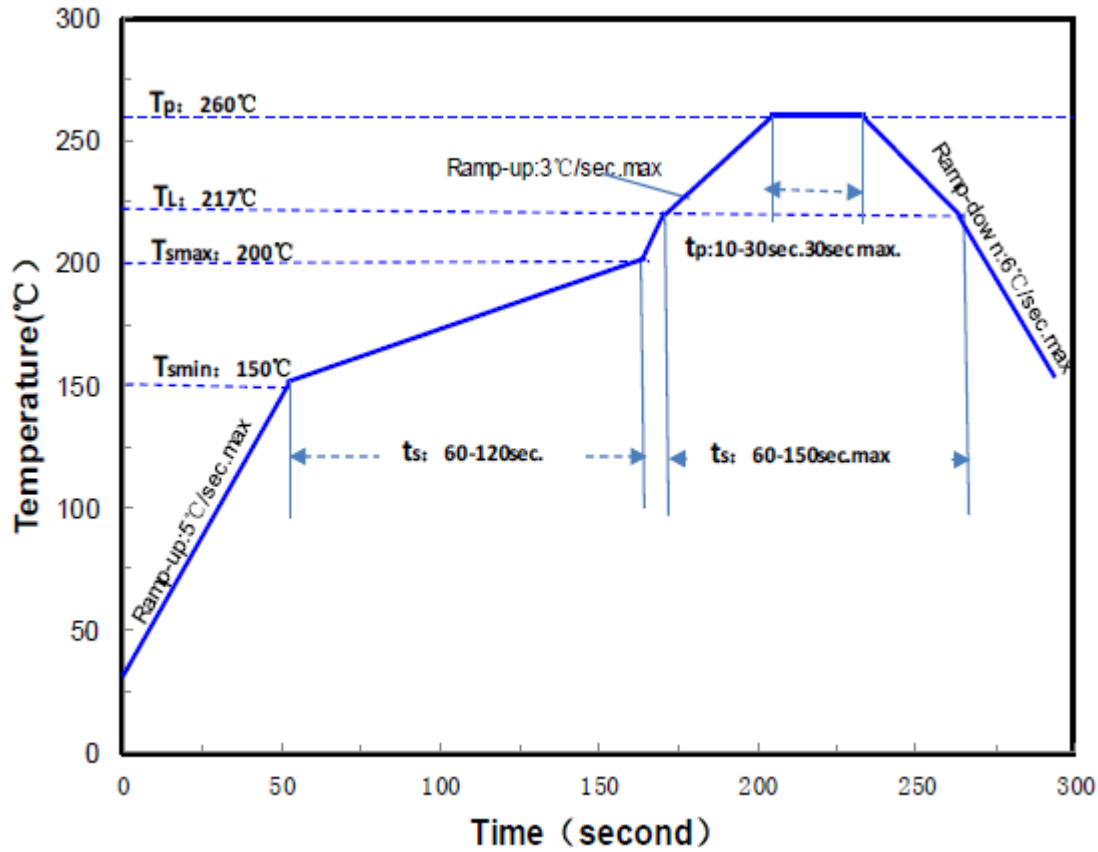

Profile Feature	Lead Free Assembly
Temperature min (T_{smin})	150°C
Temperature max(T_{smax})	200°C
Maximum time (t_s)from T_{smin} to T_{smax}	120 seconds
Ramp-up(T_L to T_P)	3°C/sec
Liquids Temperature(T_L)	217°C
Maximum Time(t_L) Maintained T_L	150 seconds
Maximum Peak Package Body Temperature(T_p)	260°C
Time Within 5°C of the Specified Temperature	10-30seconds
Maximum Ramp-Down Rate(T_p to T_L)	6°C/seconds
Maximum Time 25°C to Peak Temperature	8minutes

·Repairing

Repair should not be done after the LEDs have been soldered. When repairing is unavoidable, a double-head soldering iron should be used (as below figure). It should be confirmed in advance whether the characteristics of LEDs will or will not be damaged by repairing.

·Storage

1. Don't open the moisture proof bag before ready to use the LEDs.
2. The LEDs should be kept at 30°C or less and 65%RH or less before opening the package. The max. period before opening the package is 1 year.
3. After opening the package, the LEDs should be kept at 30°C/60%RH or less, and it should be used within 3 days. If the LEDs should be kept at 30-60%RH or more, and it should be used within 12 hours.
4. If the LEDs be kept over the conditions of 30%, baking is required before mounting. Baking conditions as below: $70 \pm 5^{\circ}\text{C}$ for 12 hours for roll goods, $105 \pm 5^{\circ}\text{C}$ for 1 hours for bulk goods.
5. The environment have no acid, alkali, corrosive gas, intensity shake and high magnetic field.

·Cautions

The encapsulated material of the LEDs is silicone. Therefore, the LEDs have a soft surface on the top of package. The pressure to the top surface will be influence to the reliability of the LEDs. Precautions should be taken to avoid the strong pressure on the encapsulated part. So, when use the picking up nozzle, the pressure on the silicone resin should be proper.