

PRODUCT SPECIFICATION

Model No.: FYL-8013UBC1B

| Descriptions: |
|--|
| <ul style="list-style-type: none"> ■ Dice material: InGaN. ■ Emitting Color: Super Bright Blue. ■ Device Outline: Φ8mm round type. ■ Lens Type: Water clear. |



| CUSTOMER APPROVED SIGNATURES | APPROVED BY | CHECKED BY | PREPARED BY |
|------------------------------|-------------|------------|-------------|
| | | | |

NINGBO FORYARD OPTOELECTRONICS CO.,LTD.

Add:No. 666 Jinghua Road, Hi-tech Park, Ningbo, Zhejiang, China

Zip:315103

Tel: 0086-574-87933652 87922206 87927870

Fax: 0086-574-87927917

E-mail:Sales@foryard.com (General)

Model No.: FYL-8013UBC1B

■ Absolute Maximun Ratings(Ta=25°C)

| Parameter | MAX. | Unit |
|---|---------------------|-------|
| Power Dissipation | 100 | mW |
| Peak Forward Current (1/10 Duty Cycle, 0.1ms Pulse Width) | 100 | mA |
| Continuous Forward Current | 30 | mA |
| Derating Linear From 50°C | 0.4 | mA/°C |
| Reverse Voltage | 5 | V |
| Operating Temperature Range | -40°C to +85°C | |
| Storage Temperature Range | -40°C to +100°C | |
| Lead Soldering Temperature[4mm(.157") From Body] | 260°C for 5 Seconds | |

■ Typical Electrical & Optical Charcteristics(Ta=25°C)

| Parameter | Symbol | Min. | Typ. | Max. | Unit | Test Condition |
|--------------------------|-----------------|------|------|-------|---------|----------------|
| Luminous Intensity | I_v | 4750 | 7500 | 10800 | mcd | IF=20mA |
| Viewing Angle | $2\theta_{1/2}$ | --- | 15 | --- | Deg | |
| Peak Emission Wavelength | λ_p | --- | 470 | -- | nm | |
| Dominant Wavelength | λ_d | 461 | 467 | 473 | nm | |
| Spectral Line Half-Width | $\Delta\lambda$ | --- | 30 | -- | nm | |
| Forward Voltage | V_F | 2.6 | 3 | 3.4 | V | VR=5V |
| Reverse Current | I_R | --- | --- | 10 | μA | |

Note:

- 1.Luminous Intensity is based on the Foryard standards.
- 2.Pay attention about static for InGaN

Model No.: FYL-8013UBC1B

■ Typical Eletrical/Optical Characteristics Curves(Ta=25°C Unless Otherwise Noted)

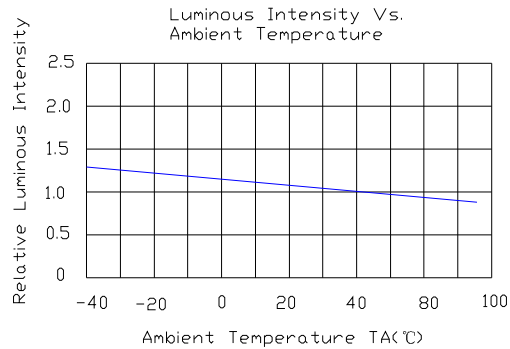
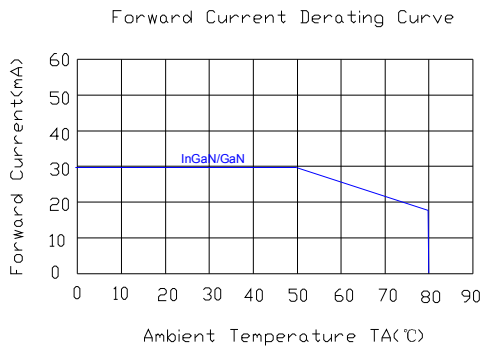
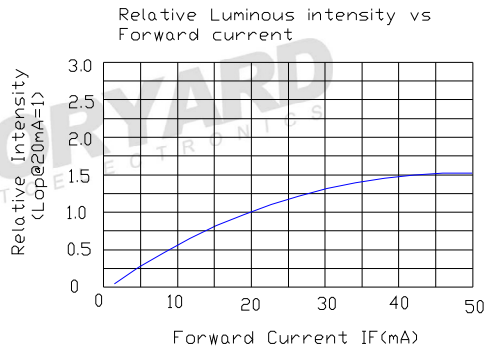
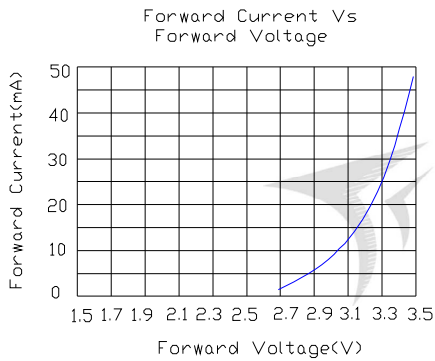
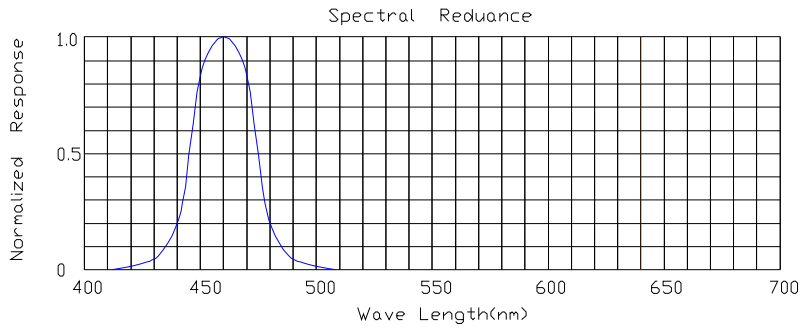

■ Radiation pattern

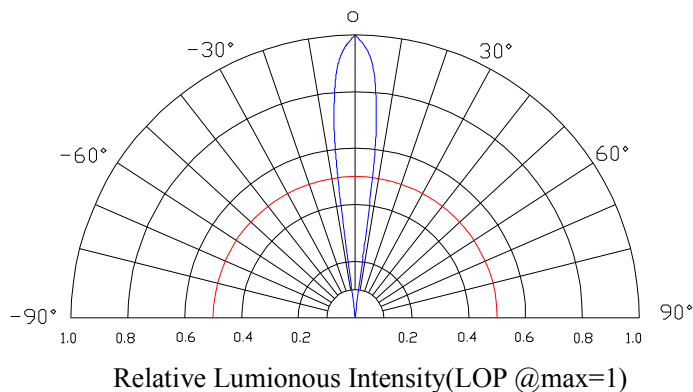

Model No.: FYL-8013UBC1B

■ LAMP PACKING.

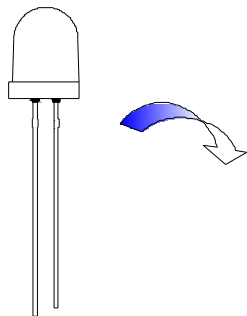

8mm 250PCS/Polybag

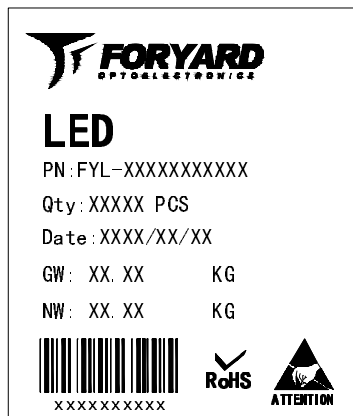
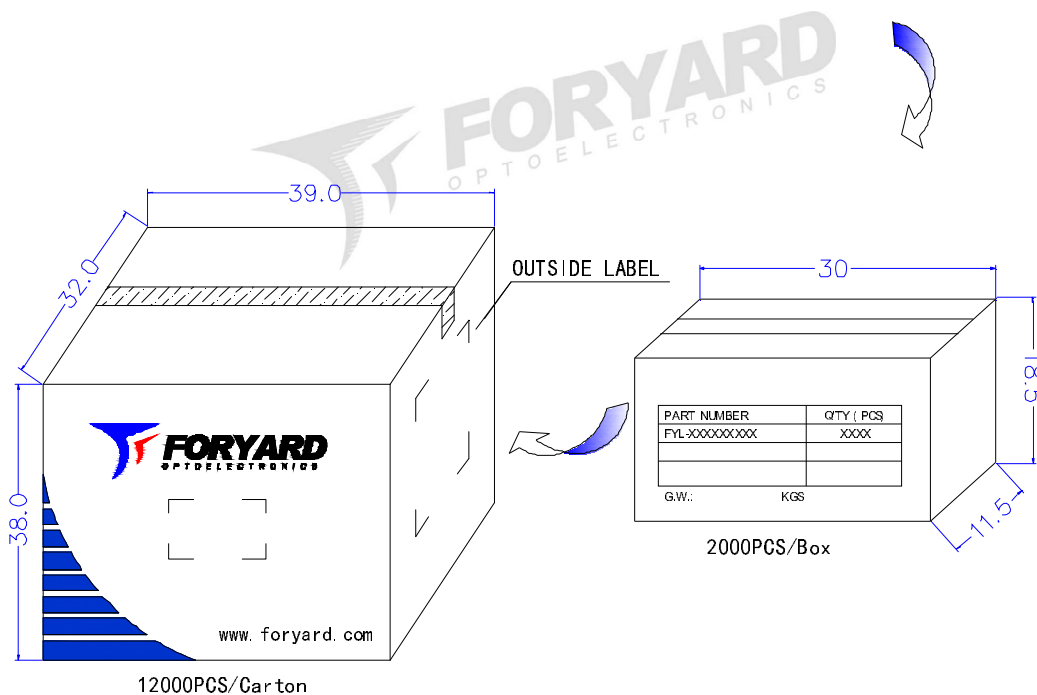

OUTSIDE LABEL

Note: The specifications are subject to change without notice. Please contact us for updated information.