

## 1A up to 40V Input Step-Down DC/DC Regulator ME3116

### General Description

The ME3116 is PWM DC/DC buck (step-down) regulators. With a wide input range from 4.75V-40V, they are suitable for a wide range of applications such as power conditioning from unregulated sources. They feature a low  $R_{DS(ON)}$  (0.9 $\Omega$  typical) internal switch for maximum efficiency 90%. Operating frequency is fixed at 550 KHz allowing the use of small external components while still being able to have low output voltage ripple. The system has PWM and PFM switching function to ensure high efficiency under low load. The built-in soft-start prevents inrush current at turn-on. The ME3116 is optimized for up to 1A load current. Both have a 0.8V nominal feedback voltage. Additional features include: thermal shutdown,  $V_{IN}$  under-voltage lockout, and gate drive under-voltage lockout.

### Selection Guide

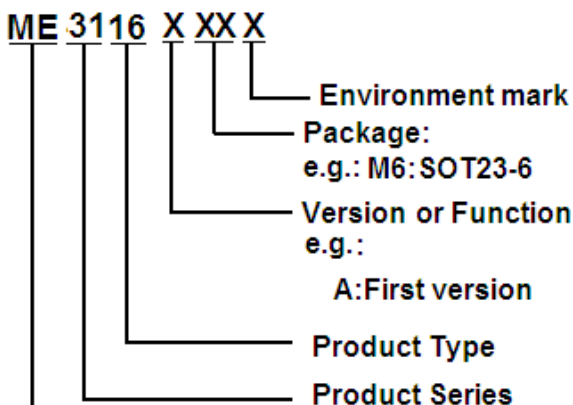

### Features

- Feedback pin voltage of 0.8V
- Input voltage range of 4.75V to 40V
- Output current up to 1A
- 550 KHz switching frequency
- maximum efficiency 90%
- PWM and PFM switching
- Low shutdown  $I_Q$ , 10  $\mu$ A typical
- Short circuit protected
- Internally compensated
- Soft-start circuitry
- SOT23-6 package

### Applications

- Battery powered equipment
- Industrial distributed power applications
- Portable media players
- Portable hand held instruments

### Typical Application Circuit

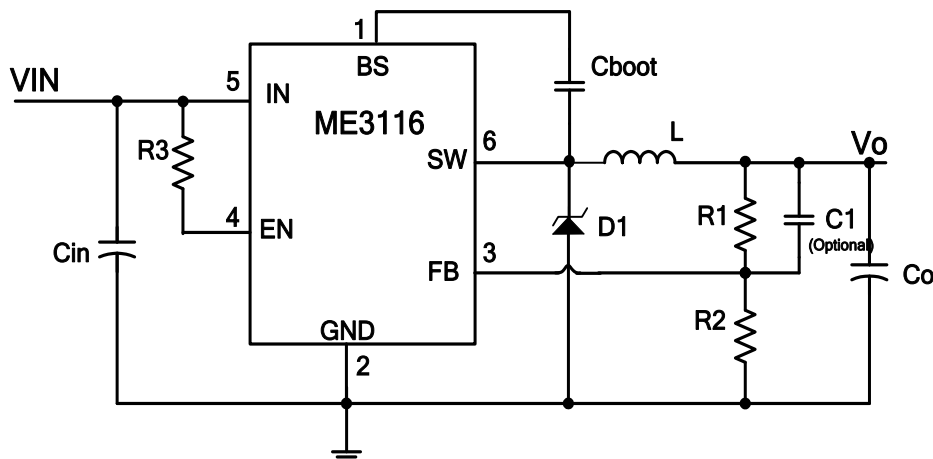

## Pin Configuration

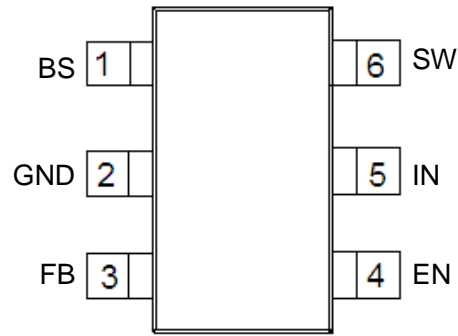

## Pin Assignment

Pin Num.	Symbol	Function
1	BS	SW FET gate bias voltage. Connect C <sub>BOOT</sub> cap between BS and SW.
2	GND	Ground
3	FB	Feedback pin: Set feedback voltage divider ratio with $V_{OUT} = V_{FB} (1 + (R1/R2))$ . Resistors should be in the 100-10KΩ range to avoid input bias errors.
4	EN	Logic level shutdown input. Pull to GND to disable the device and pull high to enable the device. If this function is not used tie to VIN with a resistor 1MΩ.
5	IN	Power input voltage pin: 4.75V to 40V normal operating range
6	SW	Power FET output: Connect to inductor, diode, and C <sub>BOOT</sub> cap.

## Absolute Maximum Ratings

Parameter	Rating	Unit
Power supply voltage, VIN	-0.3~45	V
EN voltage V <sub>EN</sub>	6	V
SW Voltage V <sub>sw</sub>	-0.3~45	V
Feedback voltage V <sub>FB</sub>	-0.3~5	V
Switch voltage V <sub>sw</sub>	-1V to 45	V
BS Voltage above SW Voltage	7	V
Maximum Junction Temperature	150	°C
Lead Temperature	300	°C
ESD Susceptibility: Human Body Model	2	KV

Caution: The absolute maximum ratings are rated values exceeding which the product could suffer physical damage.

These values must therefore not be exceeded under any conditions.

**Recommended working condition**

Parameter	Min	Max	Unit
Power supply voltage, VIN	4.75	40	V
SW voltage	-	42	V
Operating Junction Temperature Range	-40	125	°C
Storage Temperature	-65	150	°C

**Block Diagram**

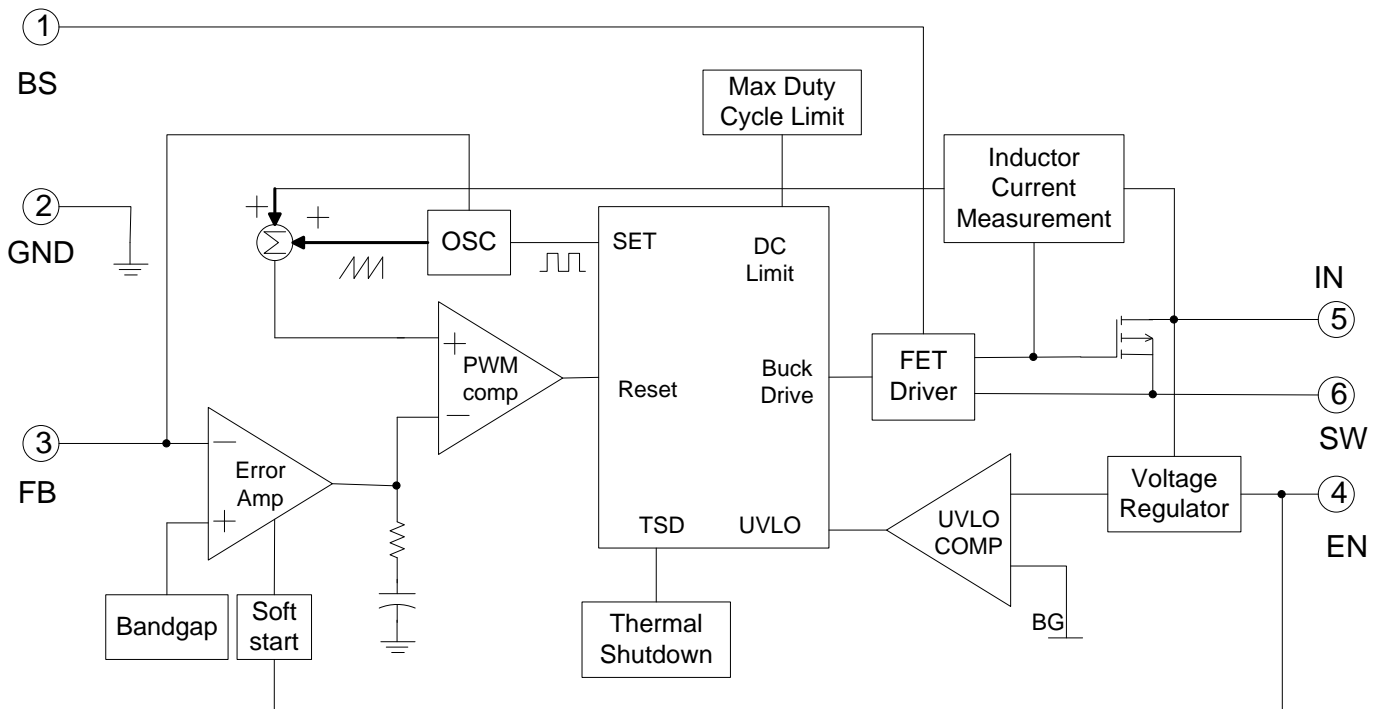

## Electrical Characteristics

Specifications in standard type face are for  $T_J = 25^\circ\text{C}$  and those with boldface type apply over the full Operating Temperature Range ( $T_J = -40^\circ\text{C}$  to  $+125^\circ\text{C}$ ). Minimum and Maximum limits are guaranteed through test, design, or statistical correlation. Typical values represent the most likely parametric norm at  $T_J = +25^\circ\text{C}$ , and are provided for reference purposes only. Unless otherwise stated the following conditions apply:  $V_{IN} = 12\text{V}$ .

Item	Symbol	Test condition	Min	Typ.	Max	Unit
Quiescent current	$I_Q$	EN=0 V	-	0.7	2	$\mu\text{A}$
		Device On, Not Switching	-	1.3	1.75	mA
		Device On, No Load	-	1.35	1.85	
Switch ON resistance	$R_{\text{DSON}}$		-	0.9	1.6	$\Omega$
Switch leakage current	$I_{\text{LSW}}$	$V_{\text{IN}} = 40\text{V}$	-	0	0.5	$\mu\text{A}$
Switch Current Limit	$I_{\text{CL}}$		-	1.2	-	A
Feedback pin Bias Current	$I_{\text{FB}}$		-	0.1	1	$\mu\text{A}$
Feedback voltage	$V_{\text{FB}}$		0.788	0.8	0.812	V
Minimum ON time	$t_{\text{MIN}}$		-	100	-	nS
Switching Frequency	$f_{\text{SW}}$	$V_{\text{FB}} = 0.5\text{V}$	-	550	-	KHz
Short Circuit Frequency	$F_{\text{short}}$	$V_{\text{FB}} = 0\text{V}$	-	140	-	KHz
Maximum Duty Cycle	$D_{\text{MAX}}$	$V_{\text{FB}} = 1.0\text{V}$	-	88	94	%
VIN UVLO Threshold	$V_{\text{uvp}}$	On threshold	4.4	3.9	-	V
	$V_{\text{uvhy}}$	Off threshold	-	3.7	3.5	V
EN Shutdown Threshold	$V_{\text{EN\_ST}}$	$V_{\text{EN}}$ Rising	4	2	-	V
Thermal Shutdown	T		-	160	-	$^\circ\text{C}$

## Application Information

The ME3116 has dedicated protection circuitry running during normal operation to protect the IC. The thermal shutdown circuitry turns off the power device when the die temperature reaches excessive levels. The UVLO comparator protects the power device during supply power startup and shutdown to prevent operation at voltages less than the minimum input voltage. A gate drive (BS) under-voltage lockout is included to guarantee that there is enough gate drive voltage to drive the MOSFET before the device tries to start switching. The ME3116 also features a shutdown mode decreasing the supply current to approximately 0.7 $\mu$ A.

## Continuous Conduction Mode

The ME3116 contains a current-mode, PWM buck regulator. A buck regulator steps the input voltage down to a lower output voltage. In continuous conduction mode (when the inductor current never reaches zero at steady state), the buck regulator operates in two cycles. The power switch is connected between VIN and SW. In the first cycle of operation the transistor is closed and the diode is reverse biased. Energy is collected in the inductor and the load current is supplied by Co and the rising current through the inductor. During the second cycle the transistor is open and the diode is forward biased due to the fact that the inductor current cannot instantaneously change direction. The energy stored in the inductor is transferred to the load and output capacitor. The ratio of these two cycles determines the output voltage. The output voltage is defined approximately as:  $D=V_o/V_{IN}$  and  $D' = (1- D)$  where D is the duty cycle of the switch. D and D' will be required for design calculations.

## Design Procedure

This section presents guidelines for selecting external components.

### Setting the Output Voltage

The output voltage is set using the feedback pin and a resistor divider connected to the output as shown on the front page schematic. The feedback pin voltage is 0.8V, so the ratio of the feedback resistors sets the output voltage

according to the following equation:  $V_o = 0.8 * \frac{R1+R2}{R2}$

Typically R2 will be given as 100 $\Omega$ -10 K $\Omega$  for a starting value. To solve for R1 given R2 and Vo use :

$$R1=R2 * \left(\frac{V_o}{0.8V} - 1\right)$$

### Feedforward Capacitor Selection

Internal compensation function allows users saving time in design and saving cost by reducing the number of external components. The use of a feedforward capacitor C1 in the feedback network is recommended to improve the transient response or higher phase margin.

For optimizing the feedforward capacitor, knowing the cross frequency is the first thing. The cross frequency (or the converter bandwidth) can be determined by using a network analyzer. When getting the cross frequency with no feedforward capacitor identified, the value of feedforward capacitor C1 can be calculated with the following equation:

$$C1 = \frac{1}{2\pi * F_{CROSS}} * \sqrt{\frac{1}{R1} * (\frac{1}{R1} + \frac{1}{R2})}$$

Where  $F_{CROSS}$  is the cross frequency. to reduce transient ripple, the feedforward capacitor value can be increased to push the cross frequency to higher region. Although this can improve transient response, it also decreases phase margin and causes more ringing. In the other hand, if more phase margin is desired, the feedforward capacitor value can be decreased to push the cross frequency to lower region. In general, the feedforward capacitor range is between 10pF to 220pF.

FB Compensation capacitor selection recommendation				Note
	R1	R2	C1	
V <sub>O</sub> =5V	5.1KΩ	1KΩ	47p-220p	VIN≤40V
	56KΩ	10KΩ	47p-100p	
	112KΩ	20KΩ	20p	
V <sub>O</sub> =3.3V	3.3KΩ	1KΩ	440p-660p	VIN≤24V
	10KΩ	3KΩ	100p-330p	
	33KΩ	10KΩ	67p-100p	
	100KΩ	30KΩ	20p	

## Input Capacitor

A low ESR ceramic capacitor (C<sub>IN</sub>) is needed between the VIN pin and GND pin. This capacitor prevents large voltage transients from appearing at the input. Use a 2.2 μF-10 μF value with X5R or X7R dielectric. Depending on construction, a ceramic capacitor's value can decrease up to 50% of its nominal value when rated voltage is applied. Consult with the capacitor manufacturer's data sheet for information on capacitor derating over voltage and temperature.

## Inductor Selection

The most critical parameters for the inductor are the inductance, peak current, and the DC resistance. The inductance is related to the peak-to-peak inductor ripple current, the input and the output voltages.

$$L = \frac{(VIN - VO) * \tau}{VIN * I_{RIPPLE} * f}$$

A higher value of ripple current reduces inductance, but increases the conductance loss, core loss, and current stress for the inductor and switch devices. It also requires a bigger output capacitor for the same output voltage ripple requirement. A reasonable value is setting the ripple current to be 30% of the DC output current. Since the ripple current increases with the input voltage, the maximum input voltage is always used to determine the inductance. The DC resistance of the inductor is a key parameter for the efficiency. Lower DC resistance is available with a bigger winding area. A good tradeoff between the efficiency and the core size is letting the inductor copper loss equal 2% of the output power. A good starting point for most applications is a 4.7μH to 15μH with 1A or greater current rating for the ME3116. Using such a rating will enable the ME3116 to current limit without saturating the inductor. This is preferable to the ME3116 going into thermal shutdown mode and the possibility of damaging the inductor if the output is shorted to ground or other long term overload.

## Output Capacitor

The selection of Co is driven by the maximum allowable output voltage ripple. The output ripple in the constant

frequency, PWM mode is approximated by: 
$$V_{\text{RIPPLE}} = I_{\text{RIPPLE}} * \left( \text{ESR} + \frac{1}{8 * f_{\text{SW}} * C_{\text{O}}} \right)$$

The ESR term usually plays the dominant role in determining the voltage ripple. Low ESR ceramic capacitors are recommended. Capacitors in the range of 22μF-100μF are a good starting point with an ESR of 0.1Ω or less.

## Bootstrap Capacitor

A 0.15μF ceramic capacitor or larger is recommended for the bootstrap capacitor (Cboot). For applications where the input voltage is less than twice the output voltage a larger capacitor is recommended, generally 0.15μF to 1μF to ensure plenty of gate drive for the internal switches and a consistently low R<sub>DS(ON)</sub>.

## Soft-Start

The built-in soft start, controlled by the clock signal frequency, in order to prevent the current overshoot when opening.

## Shutdown Operation

The EN pin of the ME3116 is designed so that it may be controlled using 1.5V or higher logic signals. If the shutdown function is not to be used the EN pin may be tied to VIN with a resistor (A 1MΩ or larger resistor is recommended between the input voltage and the EN pin to protect the device.) . The maximum voltage to the EN pin should not exceed 5V.

## Schottky Diode

The breakdown voltage rating of the diode (D1) is preferred to be 25% higher than the maximum input voltage. The

circuit rent rating for the diode should be equal to the maximum output current for best reliability in most applications. In cases where the input voltage is much greater than the output voltage the average diode current is lower. In this case it is possible to use a diode with a lower average current rating, approximately  $(1-D)I_o$ , however the peak current rating should be higher than the maximum load current 0.5A to 1A rated diode is a good starting point.

## Layout Considerations

To reduce problems with conducted noise pick up, the ground side of the feedback network should be connected directly to the GND pin with its own connection. The feedback network, resistors R1 and R2, should be kept close to the FB pin, and away from the inductor to minimize coupling noise into the feedback pin. The input bypass capacitor  $C_{IN}$  must be placed close to the VIN pin. This will reduce copper trace resistance which effects input voltage ripple of the IC. The inductor L should be placed close to the SW pin to reduce magnetic and electrostatic noise. The output capacitor,  $C_o$  should be placed close to the junction of L and the diode D1. The L, D1, and  $C_o$  trace should be as short as possible to reduce conducted and radiated noise and increase overall efficiency. The ground connection for the diode,  $C_{IN}$ , and  $C_o$  should be as small as possible and tied to the system ground plane in only one spot (preferably at the  $C_o$  ground point) to minimize conducted noise in the system ground plane.

## Typical Performance Characteristics

T =25°C, unless otherwise noted.

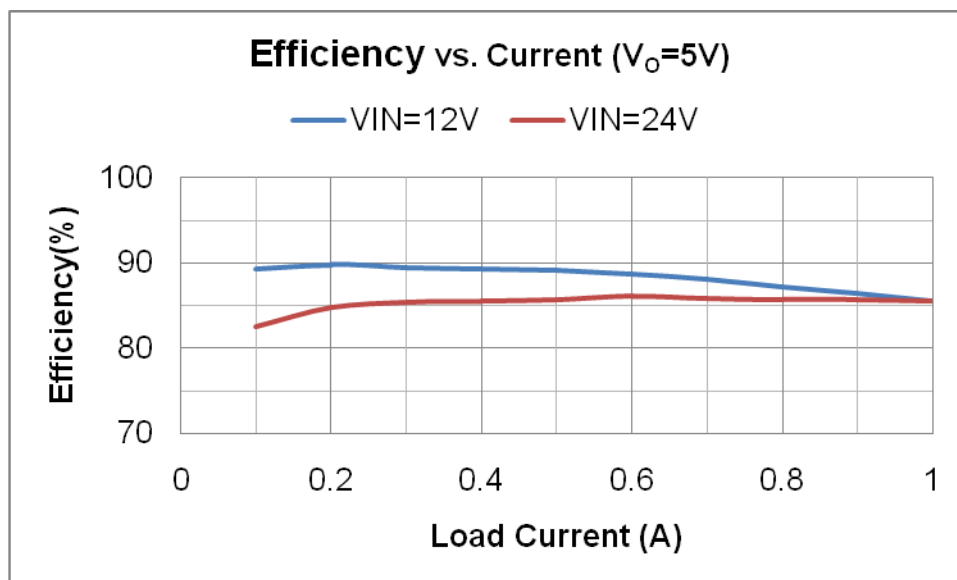

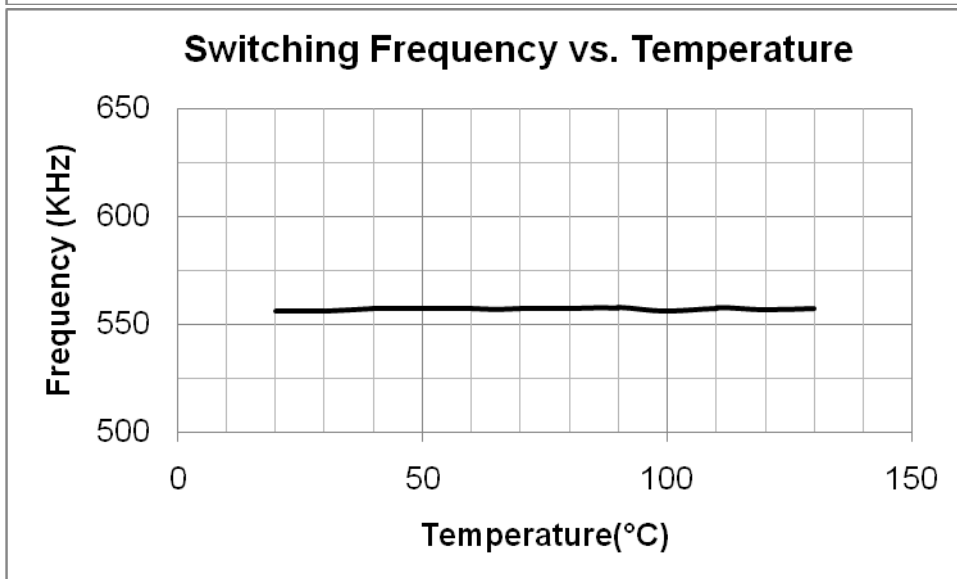
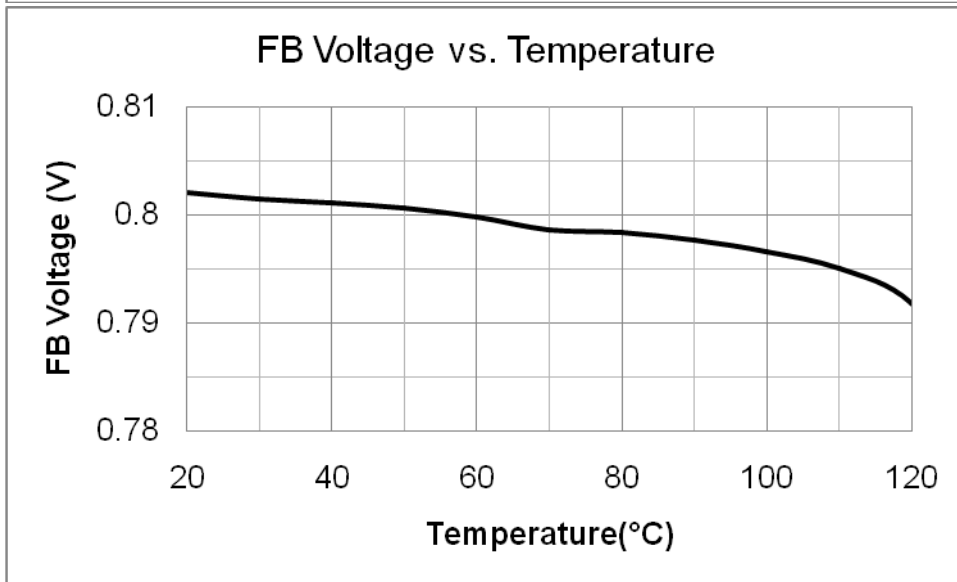
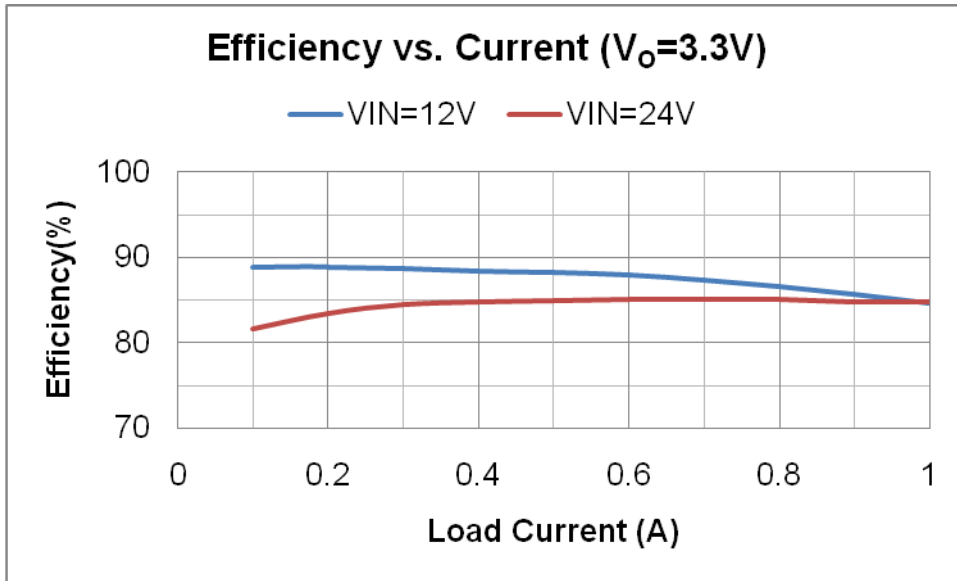

Start up (EN from Low to High)

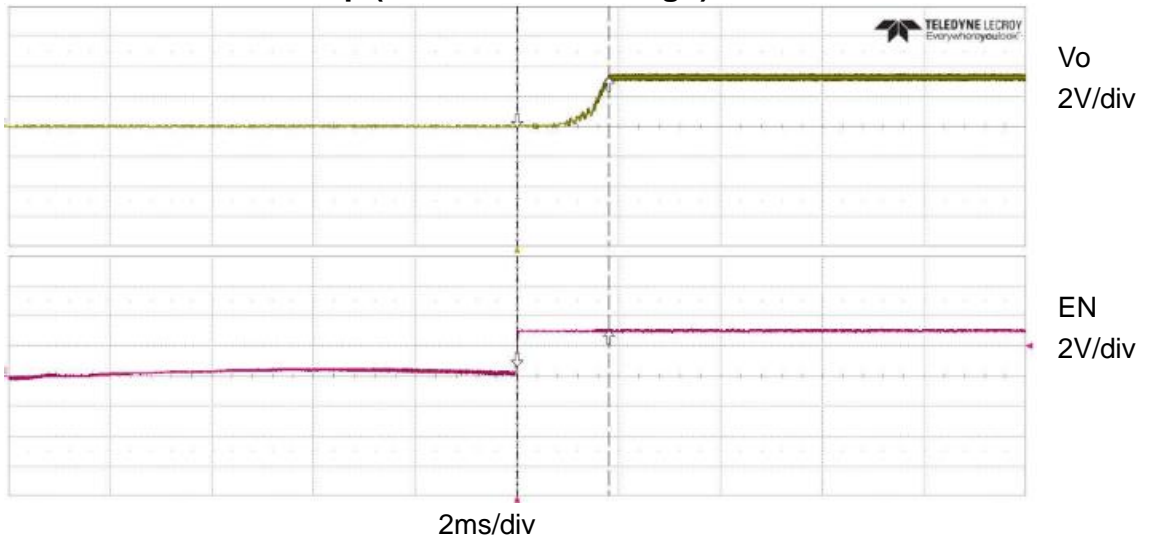

Start up (EN from High to Low)

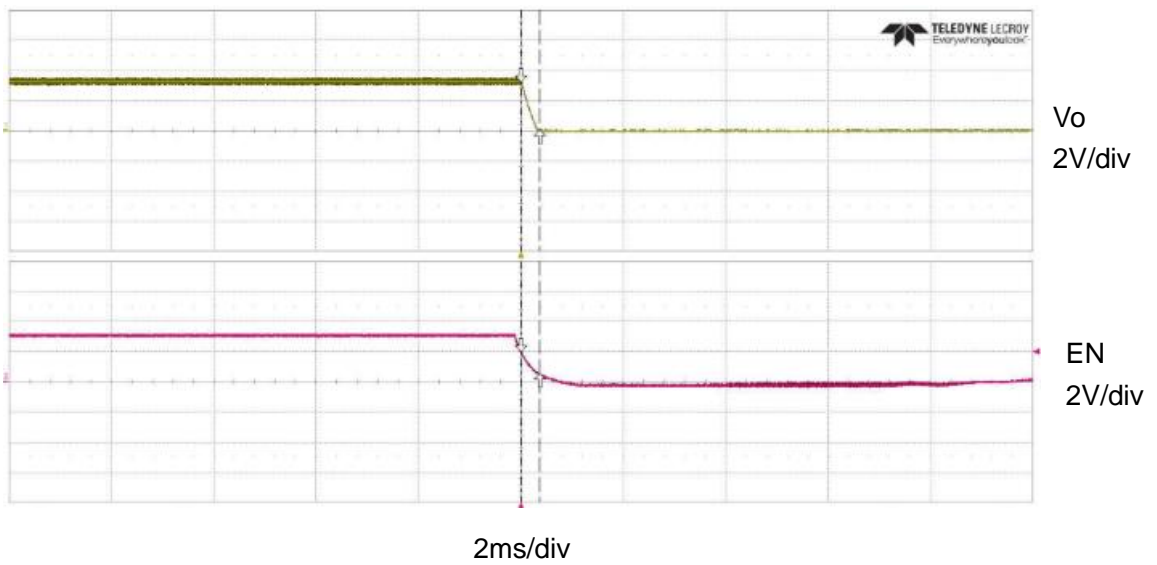

Load Transient (Load 10% to 90%)

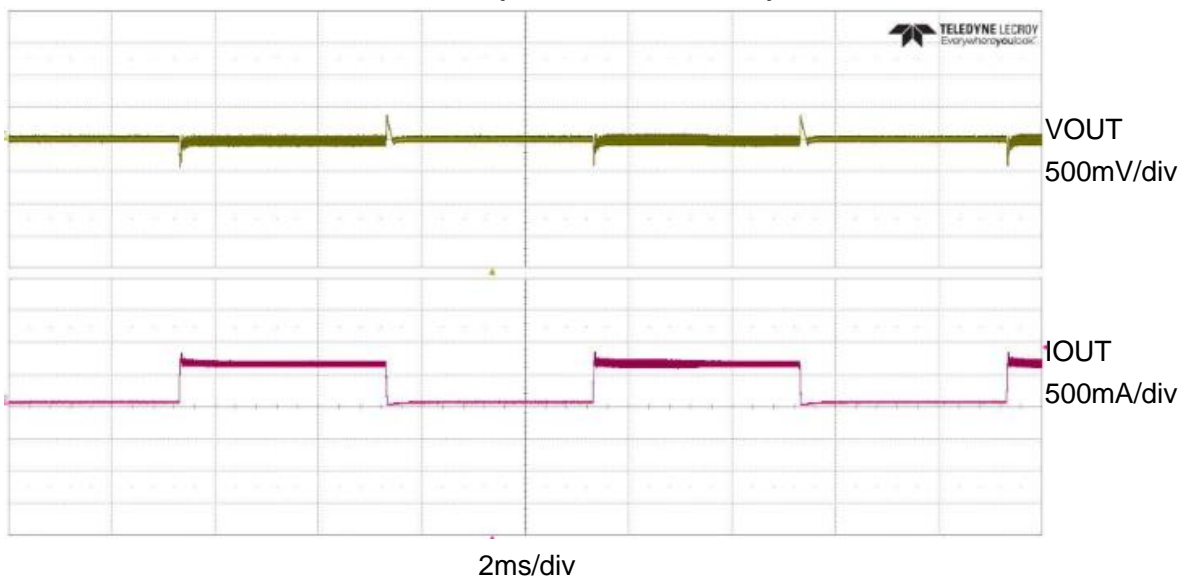

Load Transient (Load 50% to 100%)

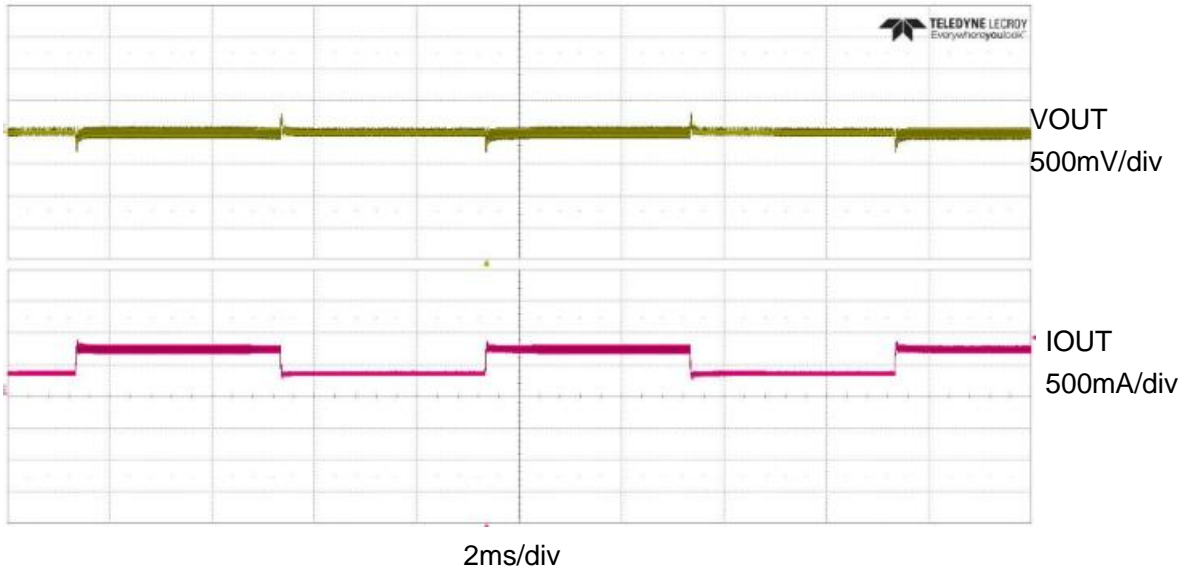

PWM and PFM switching

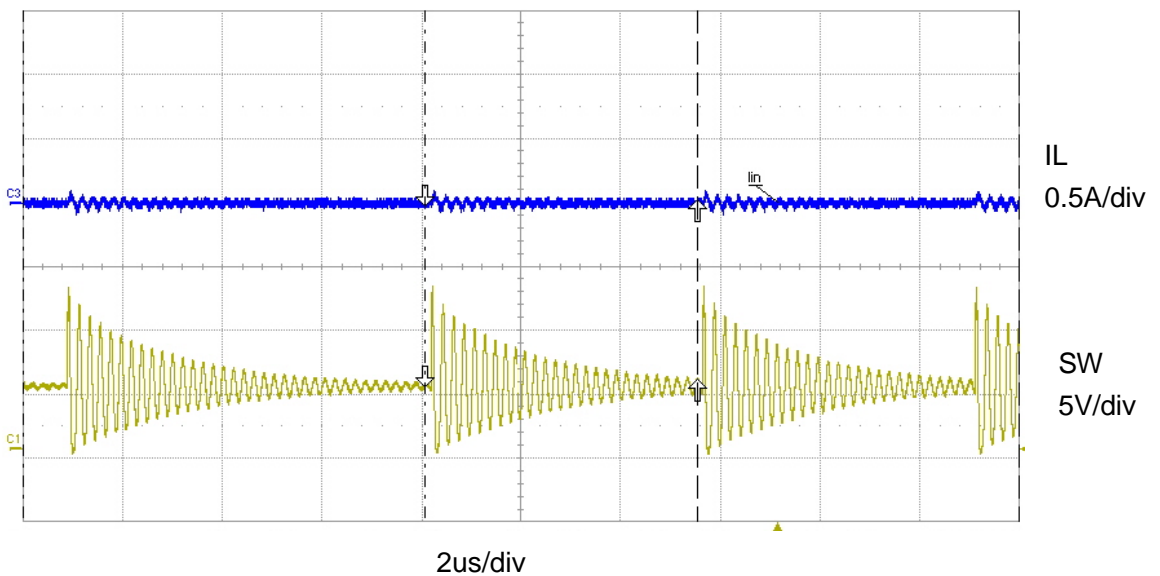
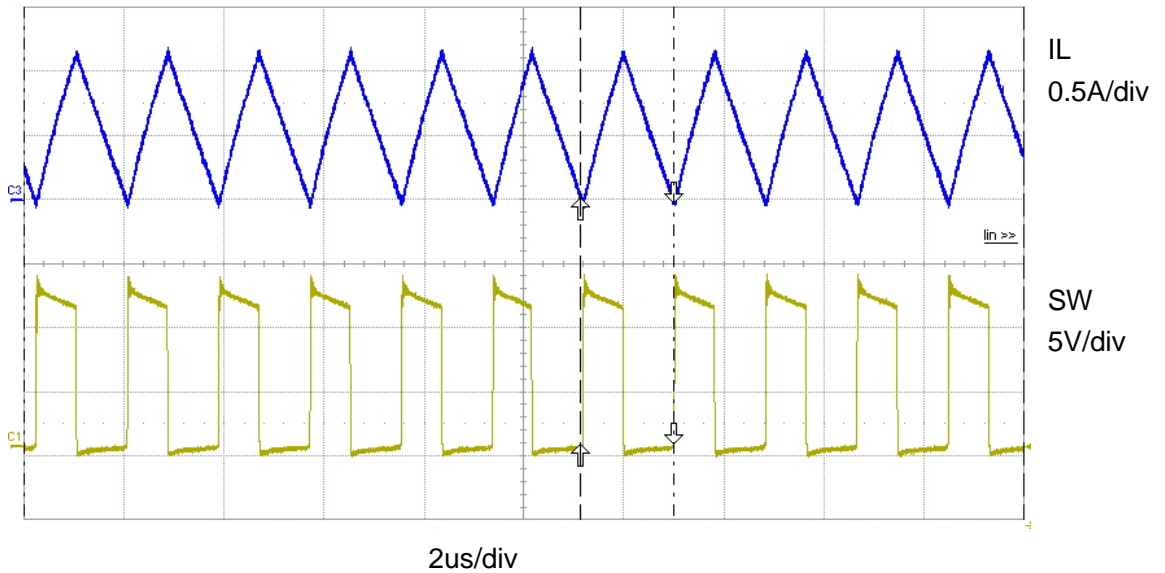

Switching Node and Output ( $I_{OUT}=600mA$ )

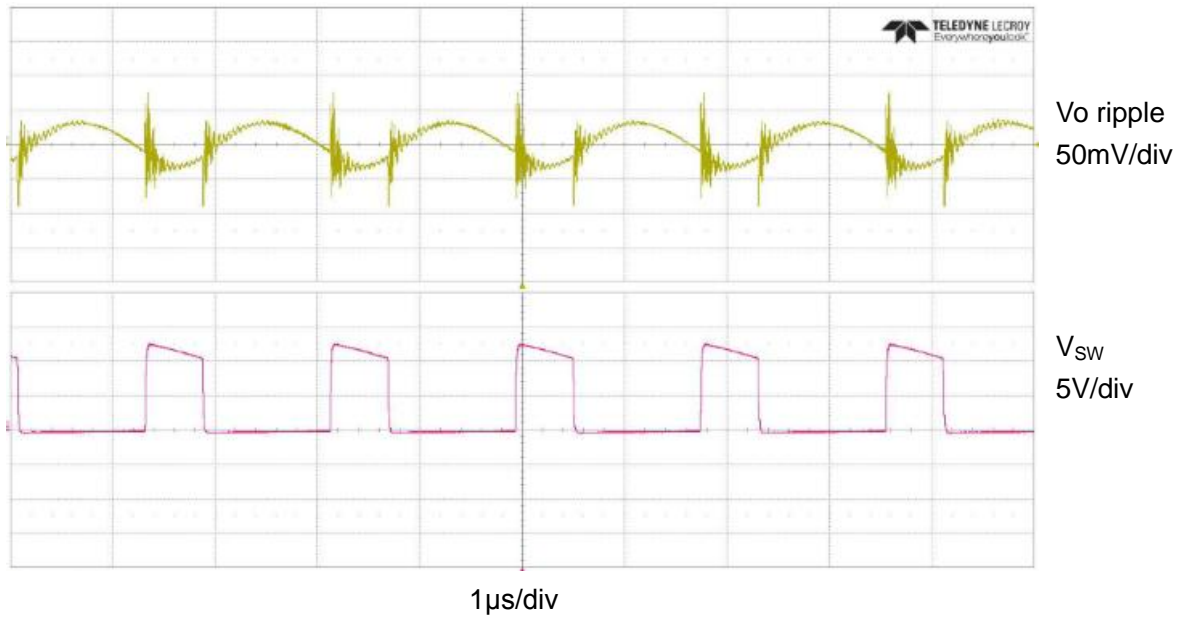

## Package Information

Package type: SOT23-6 Unit: mm(inch)

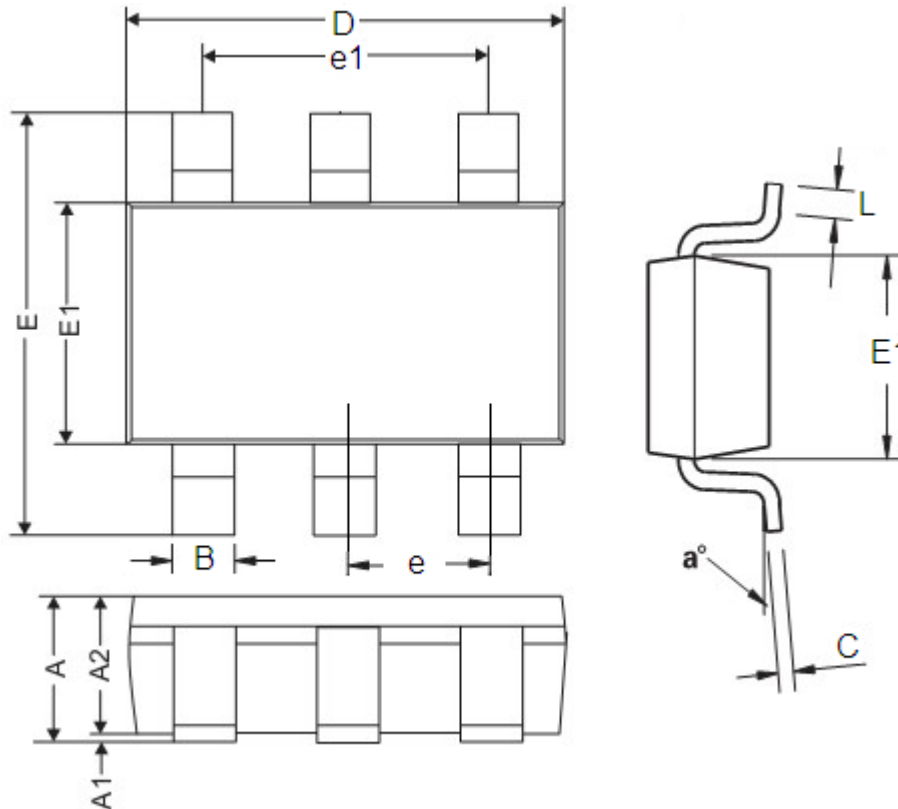

DIM	Millimeters		Inches	
	Min	Max	Min	Max
A	0.9	1.45	0.0354	0.0570
A1	0	0.15	0	0.0059
A2	0.9	1.3	0.0354	0.0511
B	0.2	0.5	0.0078	0.0196
C	0.09	0.26	0.0035	0.0102
D	2.7	3.10	0.1062	0.1220
E	2.2	3.2	0.0866	0.1181
E1	1.30	1.80	0.0511	0.0708
e	0.95REF		0.0374REF	
e1	1.90REF		0.0748REF	
L	0.10	0.60	0.0039	0.0236
a°	0°	30°	0°	30°

- The information described herein is subject to change without notice.
- Nanjing Micro One Electronics Inc is not responsible for any problems caused by circuits or diagrams described herein whose related industrial properties, patents, or other rights belong to third parties. The application circuit examples explain typical applications of the products, and do not guarantee the success of any specific mass-production design.
- Use of the information described herein for other purposes and/or reproduction or copying without the express permission of Nanjing Micro One Electronics Inc is strictly prohibited.
- The products described herein cannot be used as part of any device or equipment affecting the human body, such as exercise equipment, medical equipment, security systems, gas equipment, or any apparatus installed in airplanes and other vehicles, without prior written permission of Nanjing Micro One Electronics Inc.
- Although Nanjing Micro One Electronics Inc exerts the greatest possible effort to ensure high quality and reliability, the failure or malfunction of semiconductor products may occur. The user of these products should therefore give thorough consideration to safety design, including redundancy, fire-prevention measures, and malfunction prevention, to prevent any accidents, fires, or community damage that may ensue.