

公差/General tolerances(mm)											D 0.1/10		
0	>3	>6	>10	>18	>30	>50	>80	>120	>180	>250		>315	>400
~3	~6	~10	~18	~30	~50	~80	~120	~180	~250	~315	~400	~500	~2.50
±0.12	±0.18	±0.22	±0.26	±0.31	±0.37	±0.57	±0.80	±0.93	±1.05	±1.15	±1.60	±2.20	±2.50

PCB LAYOUT

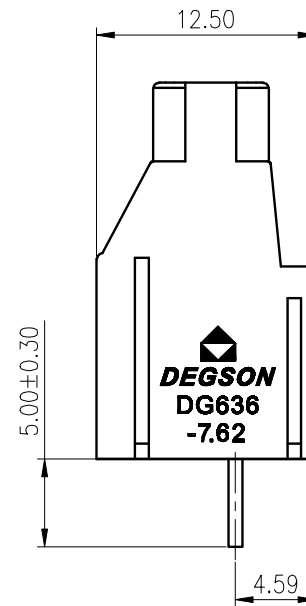
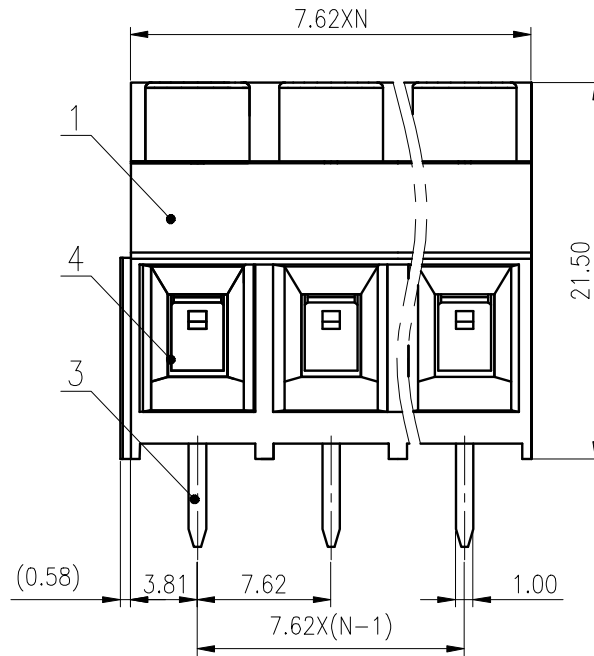
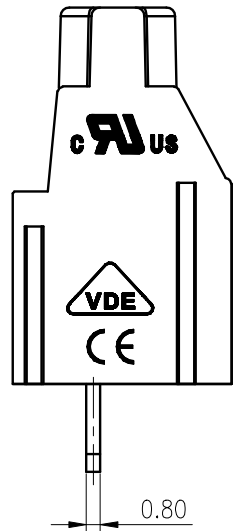
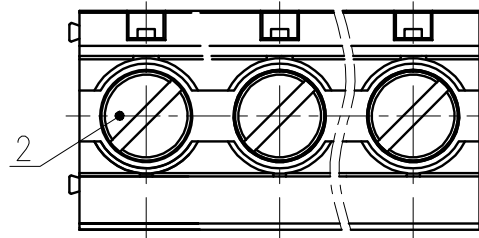
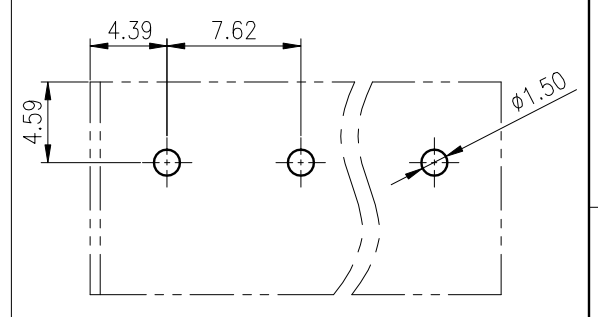

4	Cage	Copper alloy	M3/Ni Plated
3	Pin header	Copper alloy	Sn Plated
2	Screw	Steel	M3/Zn Plated
1	Housing	PA66	UL94V-0

ITEM	NAME OF PART	MATERIAL	NOTES
UL 标准/UL Standard:		B	C
额定电压/电流/Rated Voltage(V)/Current(A)		300/30	/ 300/10
IEC 标准/IEC Standard:			
过压类别/Overvoltage Category/污染等级/Pollution Degree		III/3	III/2 II/2
额定电压/电流/Rated Voltage(V)/Current(A)		/	630/32 /
工频耐压/Withstanding Voltage(KV/1Min)		/	3 /
螺丝扭矩/Torque Tightening(N·m/Lb.in)		M3, 0.5/4.43	
线径范围(硬线和软线)/Wire Range(rigid and flexible)(mm ² /AWG)		0.2~4.0(str) 0.2~6.0(sol)/26~10	
间距/Pitch(mm)/线数范围/Poles		7.62/N=02~16P	
剥线长度/Stripping length(mm)		8~9	
使用温度范围/Operating temperature(°C)		-40~+105	
符合RoHS环保要求/Conform to RoHS		Yes	

MATERIAL:	SURFACE:		
MAT NO.: /	宁波高松电子有限公司 NINGBO DEGSON ELECTRICAL CO., LTD		
STATUS: /			
APPD: Lan ChH 2020.03.18	NAME: DG636-7.62-XXP-1Y-00A(H)		
CHKD: Yu JZh 2020.03.18	DRAWING NO.: DG636-7.62-C01		
DRFT: CGM 2017.03.02	REV	T1	
SIZE: A4 TYPE: CUSTOMER DRAWING SCALE: 2.5:1 SHEET 1/1			

REV	ECN	DESCRIPTION	DRFT	DATE