

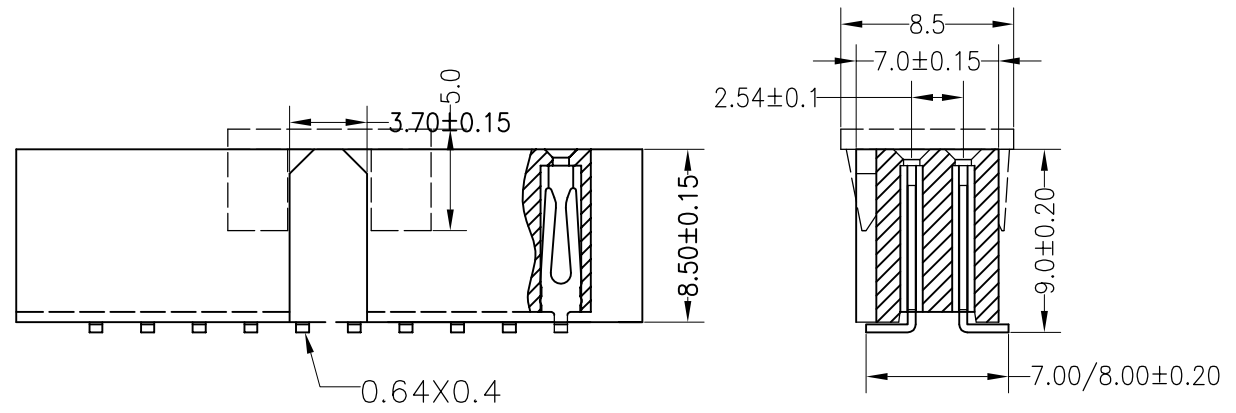

SPECIFICATIONS

Rated Current:3.0AMP
 Contact Resistance:20mΩ Max
 Withstand Voltage:1000V AC/DC
 Insulation Resistance:1000MΩ Min
 Operation Temperature:-40°c to +105°c

Contact Material:Brass
 Contact Plating:Au or Sn Over Ni
 Insulator Material:Polyester(UL94V-0)
 Standard: PA6T
 Max.Processing Temp: 230°C for 30-60 seconds
 (260°C for 10 seconds)

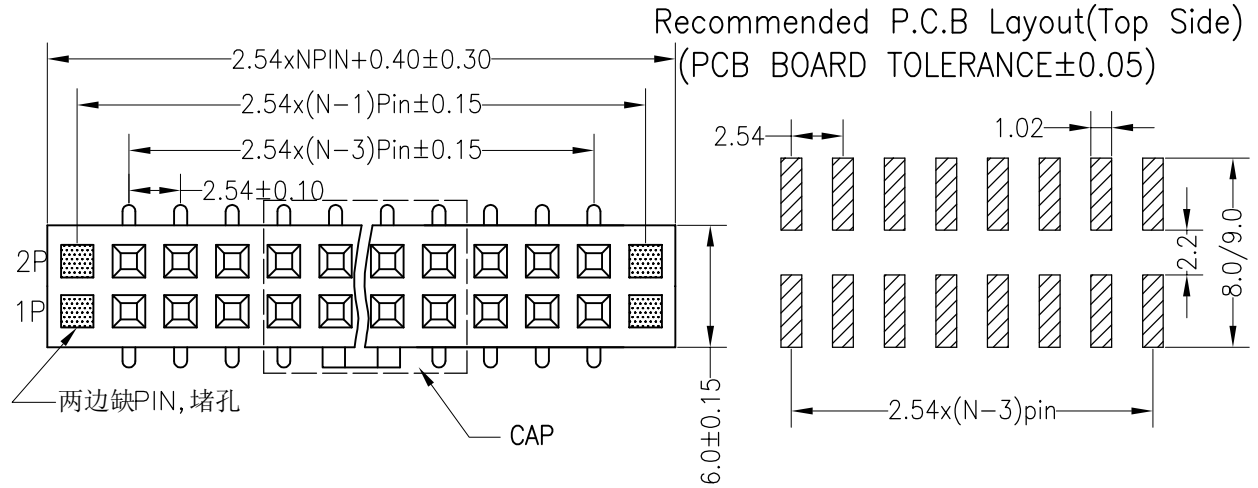

OPERATION		DRAW	YiYuSheng	12.03.28	SCALE	FIT
X.X	±0.30					
X.XX	±0.20	CHECK			UNIT	mm
X.XXX	±0.10					
Angle	±3°	APPROVE			SHEET	1/1
DIM	TOL					

NINGBO KLS ELECTRONIC CO., LTD.	
TITLE:	2.54PF H8.5mm 2xNpin 带凸W7.0mm SMT

REV	DATE	MODIFICATION DESCRIPTION	CHANGE
A0	2012.03.28	NEW DRAWING	