

## SOT-23 Plastic-Encapsulate Transistors

### FEATURES

High voltage transistor

MARKING:2D

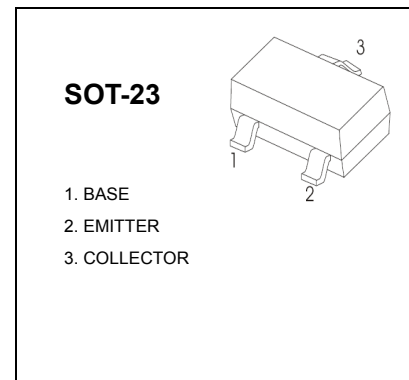

### MAXIMUM RATINGS (T<sub>a</sub>=25°C unless otherwise noted)

Symbol	Parameter	Value	Unit
V <sub>CB0</sub>	Collector-Base Voltage	-300	V
V <sub>CEO</sub>	Collector-Emitter Voltage	-300	V
V <sub>EBO</sub>	Emitter-Base Voltage	-5	V
I <sub>C</sub>	Collector Current -Continuous	-200	mA
I <sub>CM</sub>	Collector Current -Pulsed	-500	mA
P <sub>C</sub>	Collector Power Dissipation	300	mW
T <sub>j</sub>	Junction Temperature	150	°C
T <sub>stg</sub>	Storage Temperature	-55-150	°C
R <sub>θJA</sub>	Thermal Resistance From Junction To Ambient	417	°C/W

### ELECTRICAL CHARACTERISTICS (T<sub>a</sub>=25°C unless otherwise specified)

Parameter	Symbol	Test conditions	Min	Max	Unit
Collector-base breakdown voltage	V <sub>(BR)CBO</sub>	I <sub>C</sub> = -100μA, I <sub>E</sub> =0	-300		V
Collector-emitter breakdown voltage	V <sub>(BR)CEO</sub>	I <sub>C</sub> = -1mA, I <sub>B</sub> =0	-300		V
Emitter-base breakdown voltage	V <sub>(BR)EBO</sub>	I <sub>E</sub> = -100μA, I <sub>C</sub> =0	-5		V
Collector cut-off current	I <sub>CBO</sub>	V <sub>CB</sub> =-200V, I <sub>E</sub> =0		-0.25	μA
Emitter cut-off current	I <sub>EBO</sub>	V <sub>EB</sub> = -5V, I <sub>C</sub> =0		-0.1	μA
DC current gain	h <sub>FE(1)</sub>	V <sub>CE</sub> = -10V, I <sub>C</sub> = -1mA	60		
	h <sub>FE(2)</sub>	V <sub>CE</sub> = -10V, I <sub>C</sub> =-10mA	100	200	
	h <sub>FE(3)</sub>	V <sub>CE</sub> = -10V, I <sub>C</sub> =-30mA	60		
Collector-emitter saturation voltage	V <sub>CE(sat)</sub>	I <sub>C</sub> =-20mA, I <sub>B</sub> = -2mA		-0.2	V
Base-emitter saturation voltage	V <sub>BE(sat)</sub>	I <sub>C</sub> = -20mA, I <sub>B</sub> = -2mA		-0.9	V
Transition frequency	f <sub>T</sub>	V <sub>CE</sub> =-20V, I <sub>C</sub> = -10mA f=30MHz	50		MHz

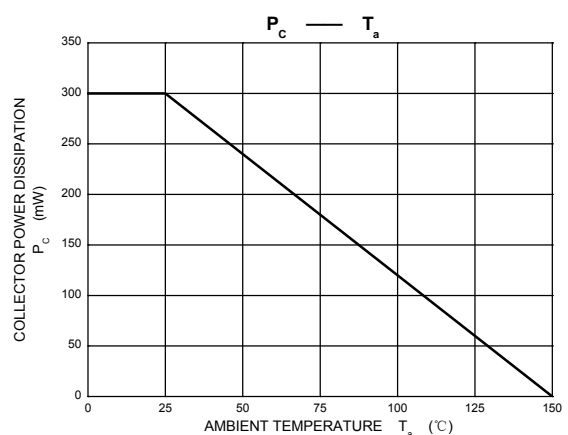
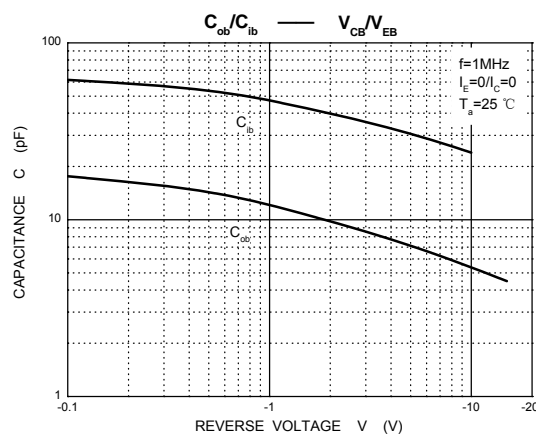
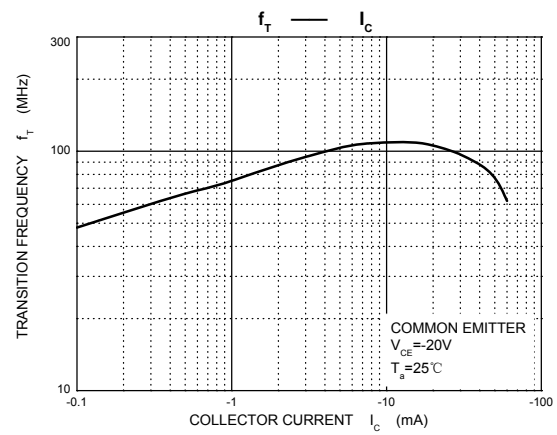
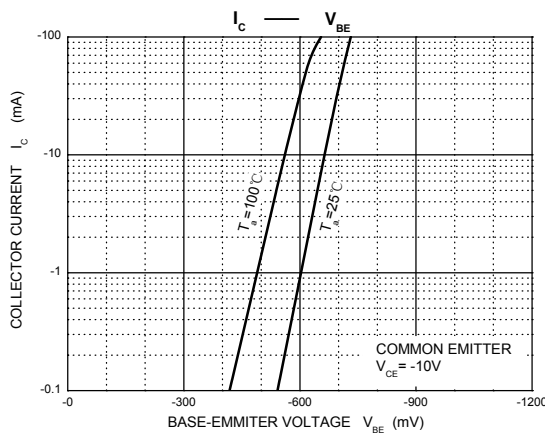
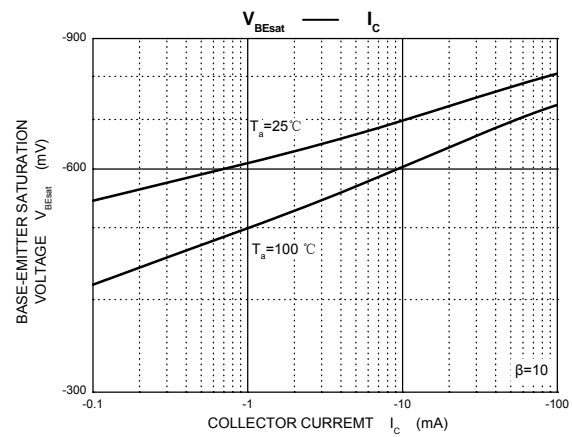
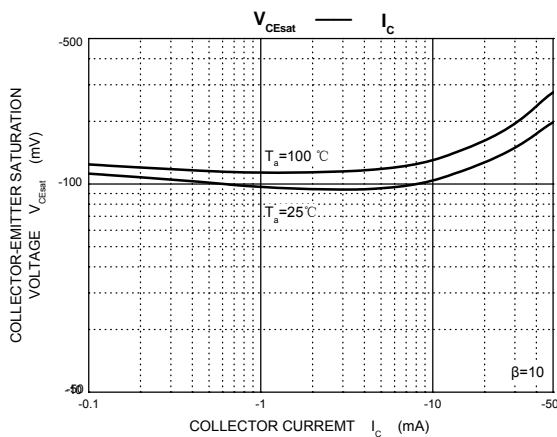
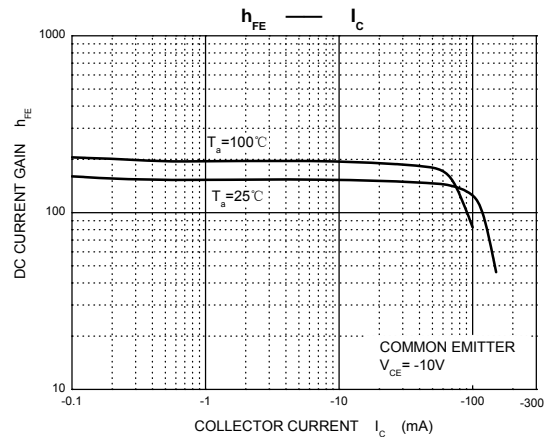
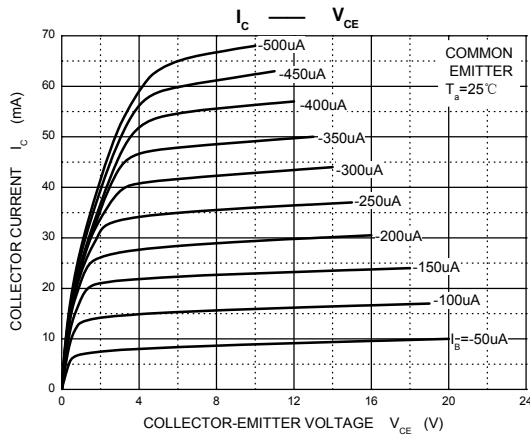
**Typical Characteristics**

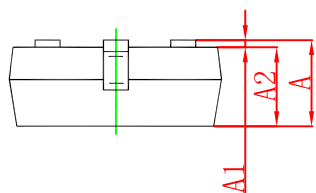
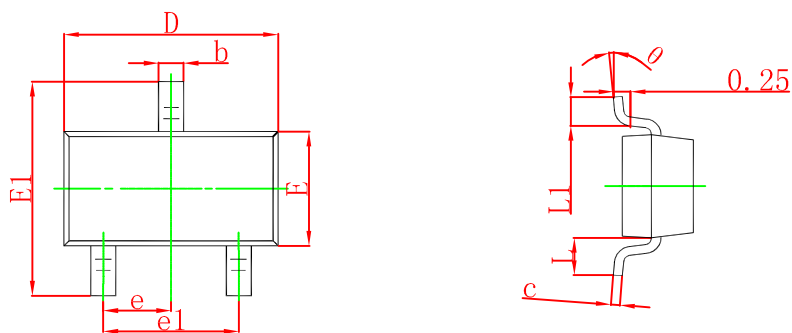

Symbol	Dimensions In Millimeters		Dimensions In Inches	
	Min	Max	Min	Max
A	0.900	1.150	0.035	0.045
A1	0.000	0.100	0.000	0.004
A2	0.900	1.050	0.035	0.041
b	0.300	0.500	0.012	0.020
c	0.080	0.150	0.003	0.006
D	2.800	3.000	0.110	0.118
E	1.200	1.400	0.047	0.055
E1	2.250	2.550	0.089	0.100
e	0.950 TYP		0.037 TYP	
e1	1.800	2.000	0.071	0.079
L	0.550 REF		0.022 REF	
L1	0.300	0.500	0.012	0.020
θ	0°	8°	0°	8°

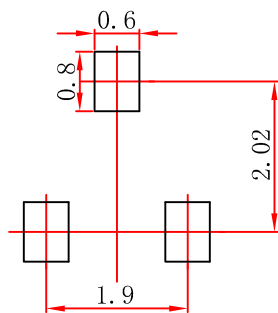
**SOT-23 Suggested Pad Layout**

- Note:
1. Controlling dimension: in millimeters.
  2. General tolerance:  $\pm 0.05\text{mm}$ .
  3. The pad layout is for reference purposes only.