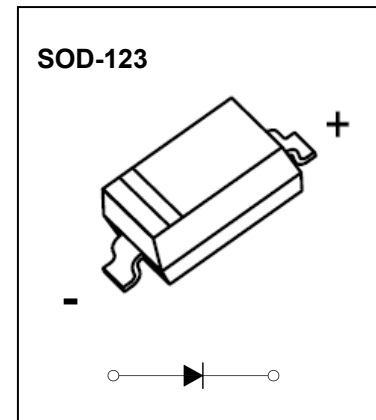
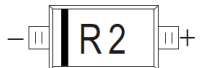
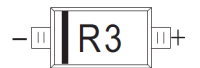
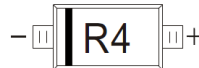
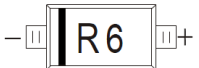
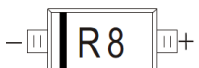

SOD-123 Plastic-Encapsulate Diodes
FEATURES

- Lead Free Finish/RoHS Compliant
- Extremely Low Thermal Resistance
- For Surface Mount Application and High Current Capability

MARKING:

STPS0520Z :R2	STPS0530 :R3	STPS0540 :R4	STPS0560 :R6	STPS0580 :R8
				

Maximum Ratings @T_a=25°C

Parameter	Symbol	STPS 0520Z	STPS 0530Z	STPS 0540Z	STPS 0560Z	STPS 0580Z	Unit
Maximum recurrent peak reverse voltage	V _{RRM}	20	30	40	60	80	V
Maximum RMS voltage	V _{RMS}	14	21	28	42	56	
Mean rectifying current	I _O	0.5					A
Non-repetitive Peak forward surge current @t=8.3ms	I _{FSM}	5.5					A
Power Dissipation	P _D	410					mW
Thermal Resistance Junction to Ambient	R _{θJA}	244					°C/W
Junction temperature	T _J	125					°C
Storage temperature	T _{stg}	-55~+150					°C

ELECTRICAL CHARACTERISTICS
T_a=25 °C unless otherwise specified

Parameter	Symbol	Min.	Typ.	Max.	Unit	Conditions
Forward voltage STPS0520Z STPS0530Z STPS0540Z STPS0560Z STPS0580Z	V _F			0.45 0.55 0.55 0.70 0.80	V	I _F =500mA
Reverse current STPS0520Z STPS0530Z STPS0540Z STPS0560Z STPS0580Z	I _R			80	μA	V _R =20V V _R =30V V _R =40V V _R =60V V _R =80V
Capacitance between terminals	C _T		30		pF	V _R =4V, f=1MHZ

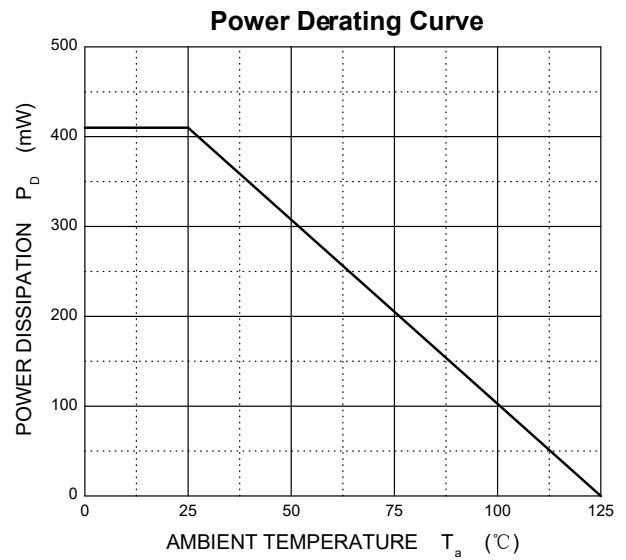
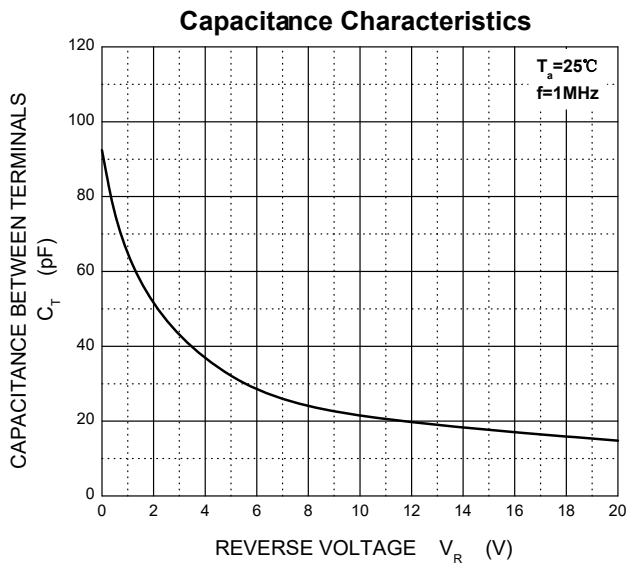
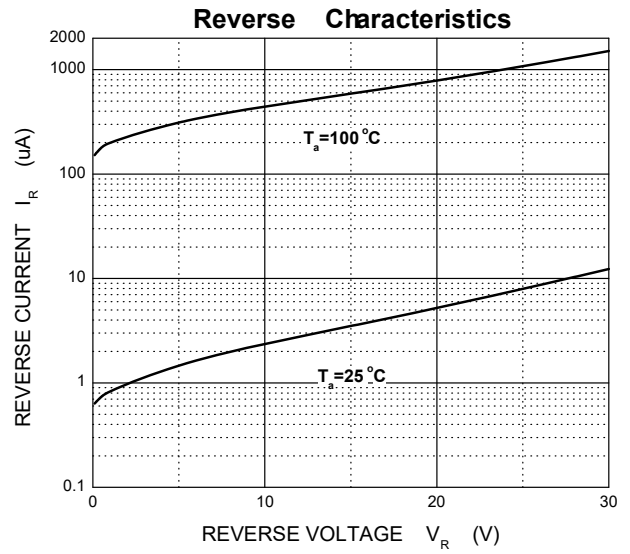
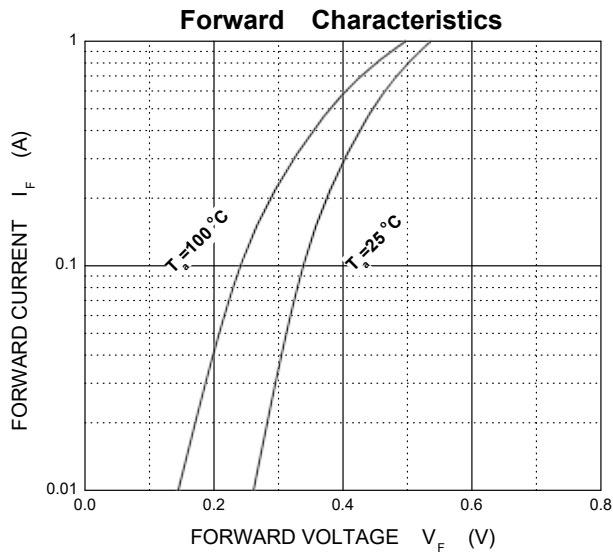
Typical Characteristics

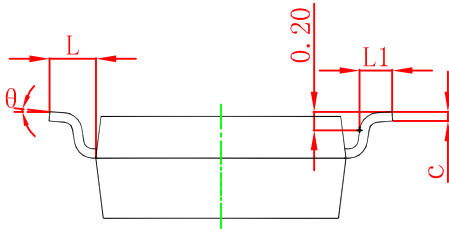
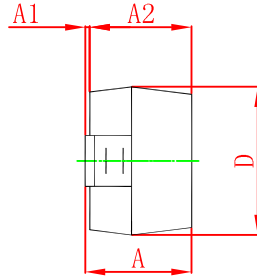
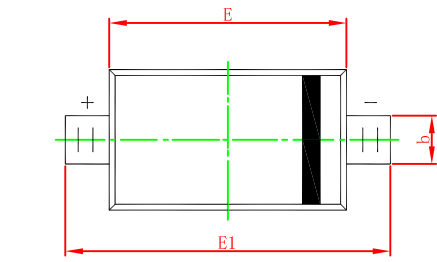

Symbol	Dimensions In Millimeters		Dimensions In Inches	
	Min	Max	Min	Max
A	1.050	1.250	0.041	0.049
A1	0.000	0.100	0.000	0.004
A2	1.050	1.150	0.041	0.045
b	0.450	0.650	0.018	0.026
c	0.080	0.150	0.003	0.006
D	1.500	1.700	0.059	0.067
E	2.600	2.800	0.102	0.110
E1	3.550	3.850	0.140	0.152
L	0.500 REF		0.020 REF	
L1	0.250	0.450	0.010	0.018
θ	0°	8°	0°	8°

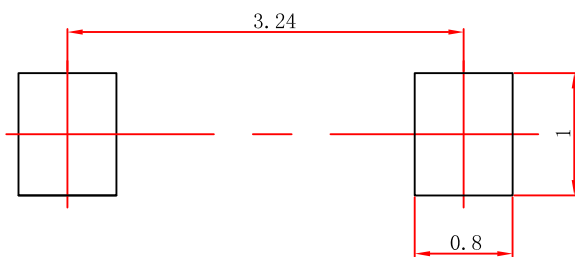
SOD-123 Suggested Pad Layout

- Note:**
1. Controlling dimension: in millimeters.
 2. General tolerance: $\pm 0.05\text{mm}$.
 3. The pad layout is for reference purposes only.